



# Chapter I

## BASICS OF AIRCRAFT & AVIATION

Subject : AVIONICS  
Class/Sem : 3<sup>rd</sup> grade/Mechatronics  
Faculty : Sivakumar N S  
Email: [sivakumar.ns@tiu.edu.iq](mailto:sivakumar.ns@tiu.edu.iq)

# Chapter I

## BASICS OF AIRCRAFT & AVIATION



# Overview of Aircraft

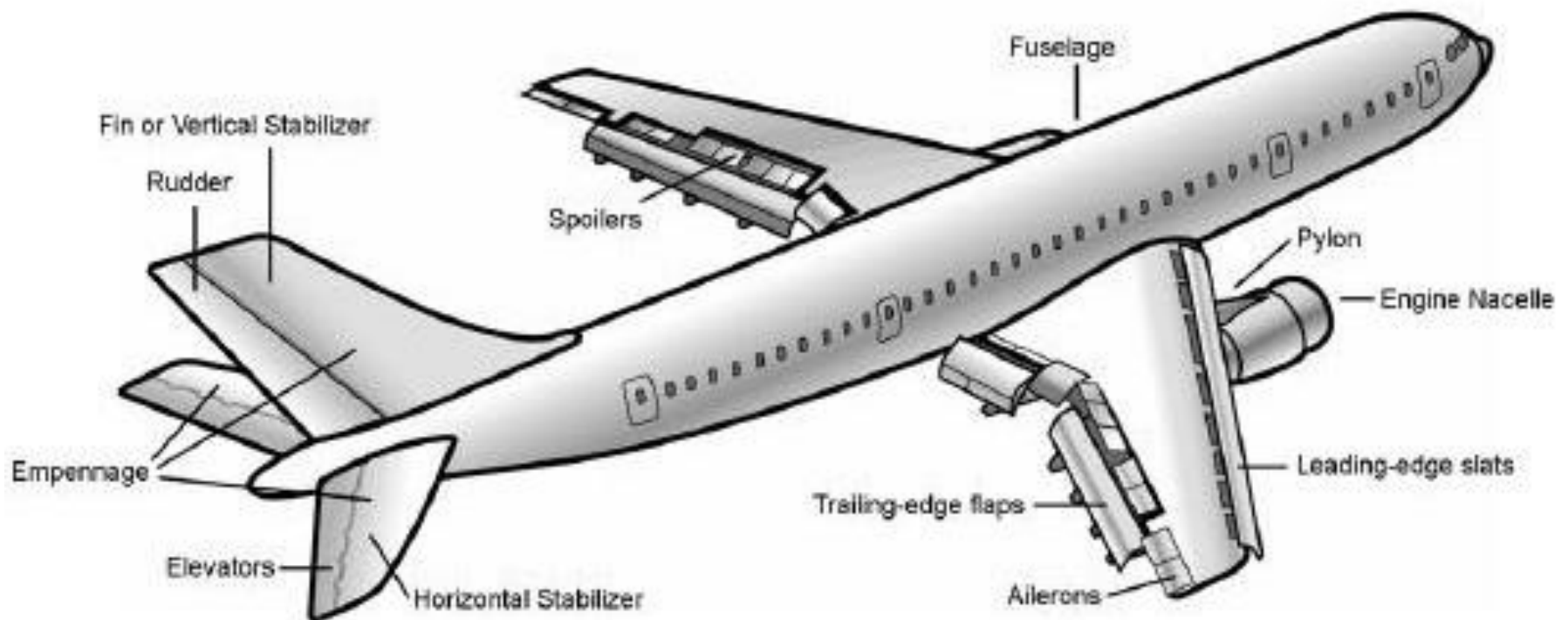

# Aircraft Structure

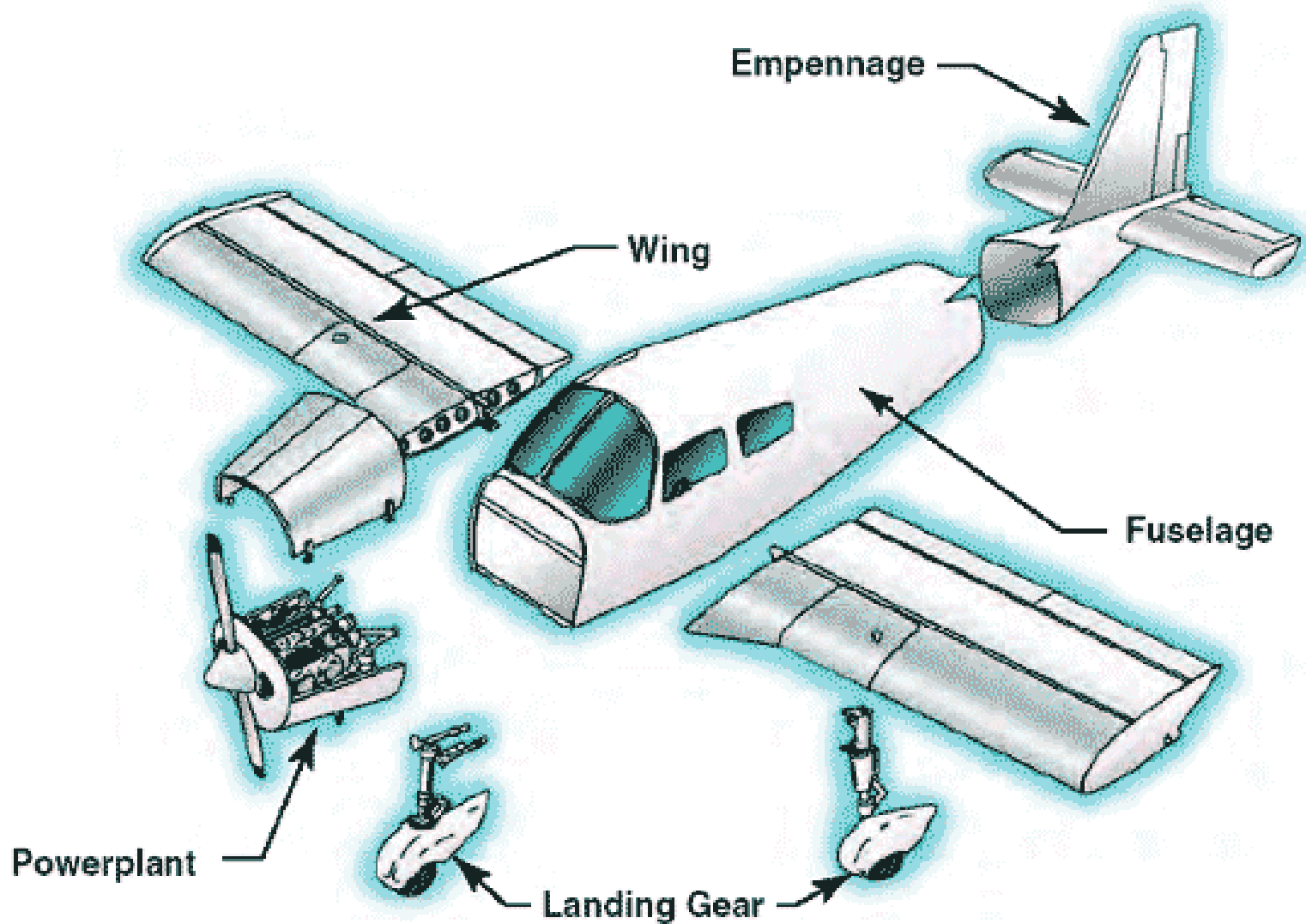

# Main Parts of a Plane

There are lots of parts in a plane, but there are main parts, such as;

The Fuselage,

The Empennage

The Wings

Power plant (Engine)

Landing Gear

We will Discuss Above in Following Slides.

# Fuselage (Body)

The Fuselage is towards the end of the plane, but it's still in the body of the plane.

It Includes the entry, emergency exits, aerials and static vents.

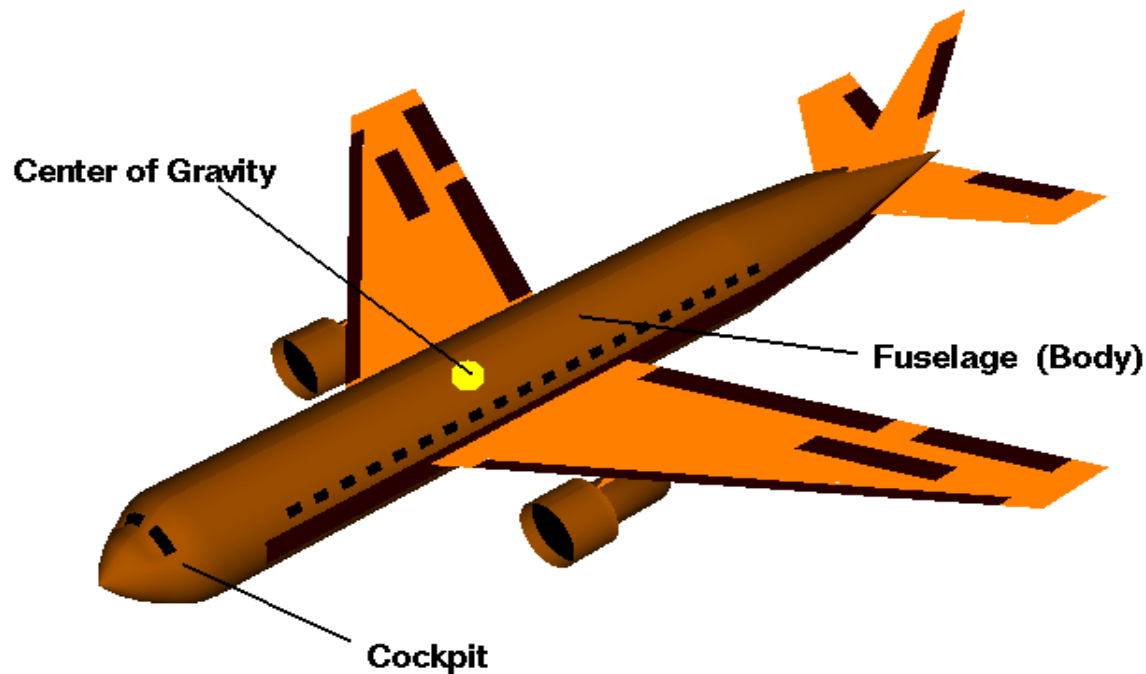

# Rudder

Rudder - Located at the end of the Empennage (tail)

It rotates to help the plane turn. The way it works is when the Rudder turns to the left, the plane goes left, and if the Rudder turns to the right, the plane goes right.

# Wings

## Wing

-Includes the leading and trailing edges, navigation lights, wind flaps, ailerons, spoilers and stall warning indicator. it allows a low pressure/high pressure to be produced on top of the wing. The advantage of having a Cambered wing is that it can be built to make the wing a lot stronger.

-If pressure is on top of wing low, then flight will lift up (lift force against weight)

-If If pressure is on top of wing high, then flight will landing (weight is acting downward)

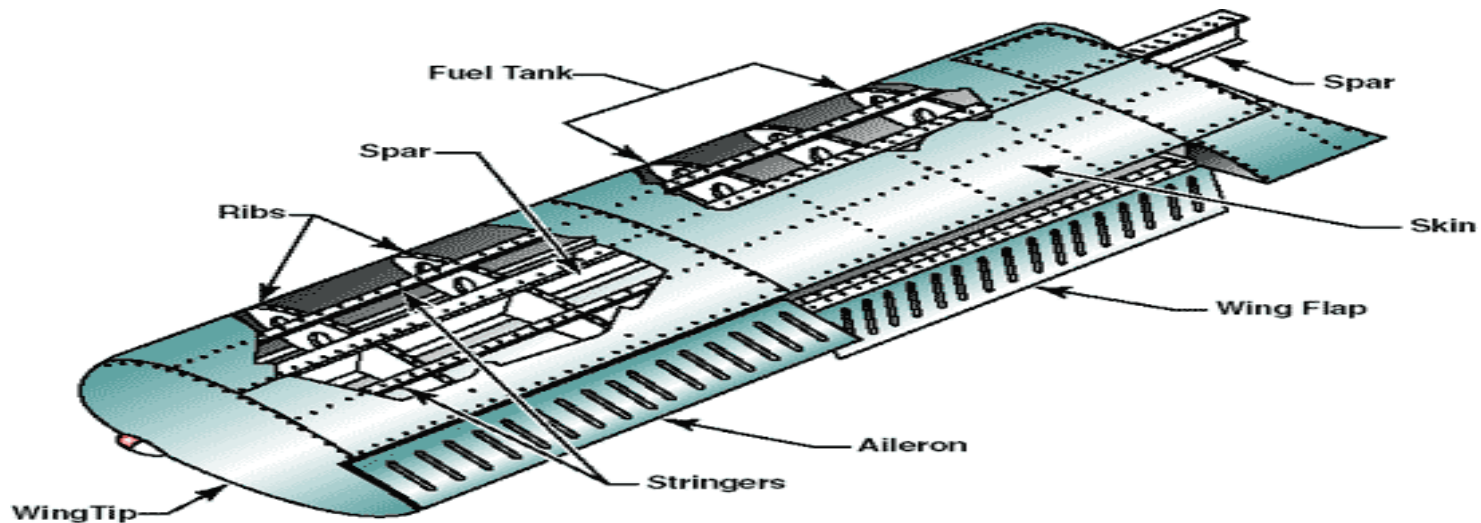



# Aileron & Flaps

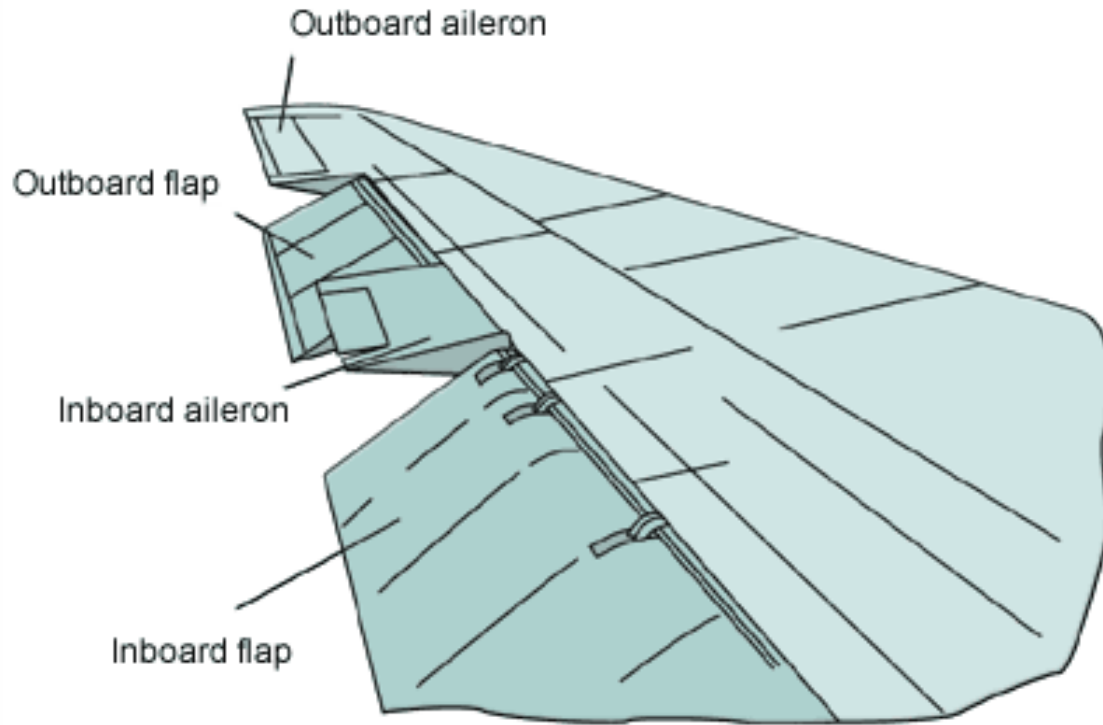

# Ailerons (For Rolling)

Ailerons assist the plane in turning. It's located on the far end of the wings.

The purpose of the Ailerons is to roll the plane, which helps it turn.

- They are much smaller than the wing flaps. When the Aileron on wing side goes up, the other wing's Aileron goes down.
- The wing with the Aileron up tilts down, and the other Aileron which is down, makes the wing go up.

Left aileron down, right one up  
causes a roll to the right

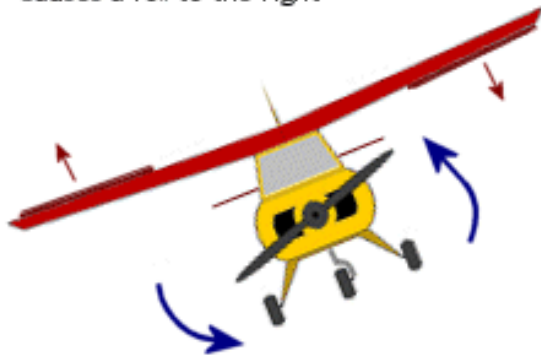

Left aileron up, right one down  
causes a roll to the left

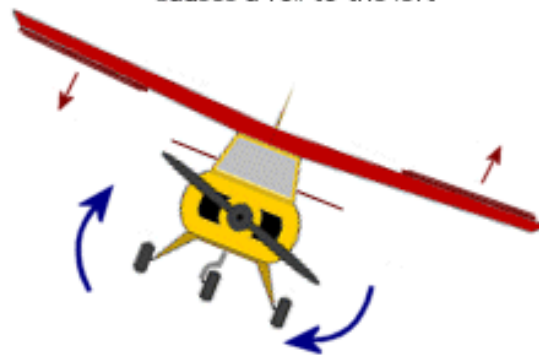

# Flaps

## (For take off & Landing)

These are important for landing.

They go down to help the plane slow down.

They also go up about 10 degrees when taking off for extra lift.

so they have controls the Pitching action (Nose and tail moving up & down is called Pitching) .

# Empennage (Tail)

The Empennage is the tail.

- Includes elevator/stabiliser, trim tabs, fin and rudder.

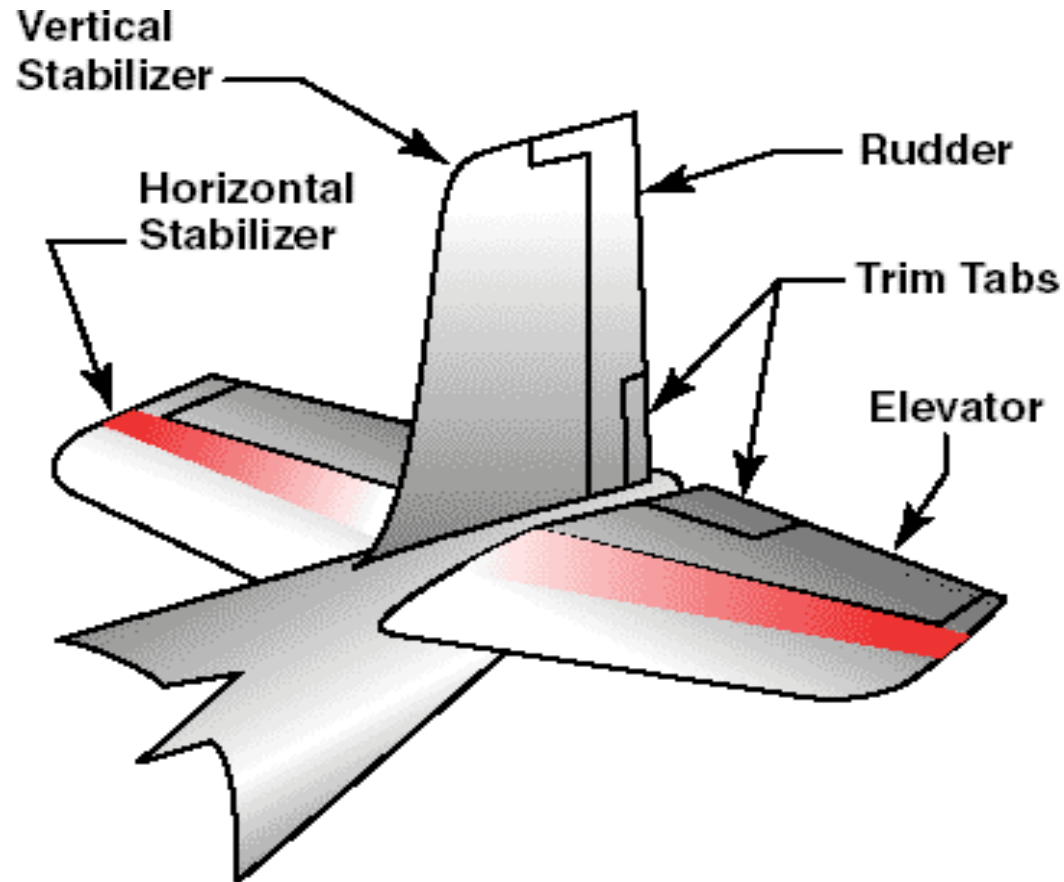

# Vertical stabilizer/ fins

- The **vertical stabilizers** or fins of aircraft, missiles or bombs are typically found on the aft end of the fuselage or body, and are intended to reduce aerodynamic side slip and provide direction stability.
- In vertical stabilizer is fixing the Rudders shown in figure.



# horizontal stabilizer

At the rear of the fuselage of most aircraft one finds a **horizontal stabilizer** or elevator. The **stabilizer** is a fixed wing section whose job is to provide stability for the aircraft, to keep it flying straight.

The **horizontal stabilizer** prevents up-and-down, or pitching, motion of the aircraft nose.

In horizontal stabilizer is fixing the elevators as shown in figure.

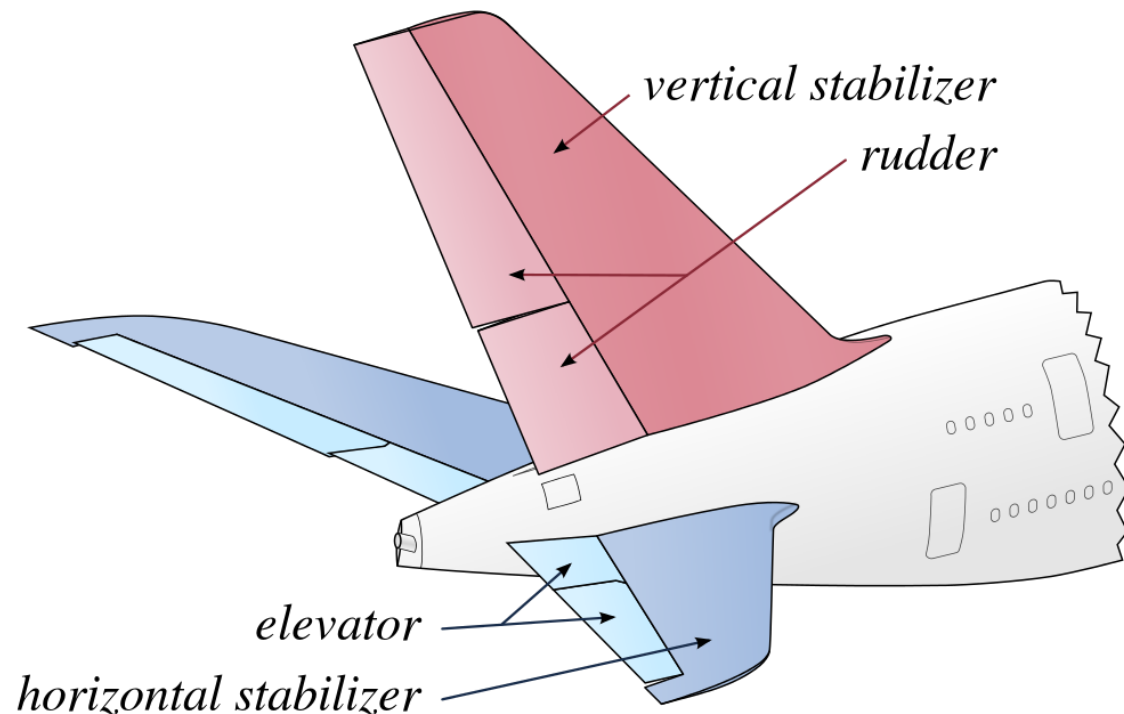

# Elevators

The Elevators are like Ailerons but they do the opposite for the plane. They help the plane go up or down.

Elevators - Located on the edge of the horizontal part of the tail

The Elevator is like the Rudder except it makes the plane descend or rise.

If the Elevators go down, the plane goes down, if they go up, the plane goes up.



# Rudder

Rudder - Located at the end of the Empennage (tail)

It rotates to help the plane turn. The way it works is when the Rudder turns to the left, the plane goes left, and if the Rudder turns to the right, the plane goes right.

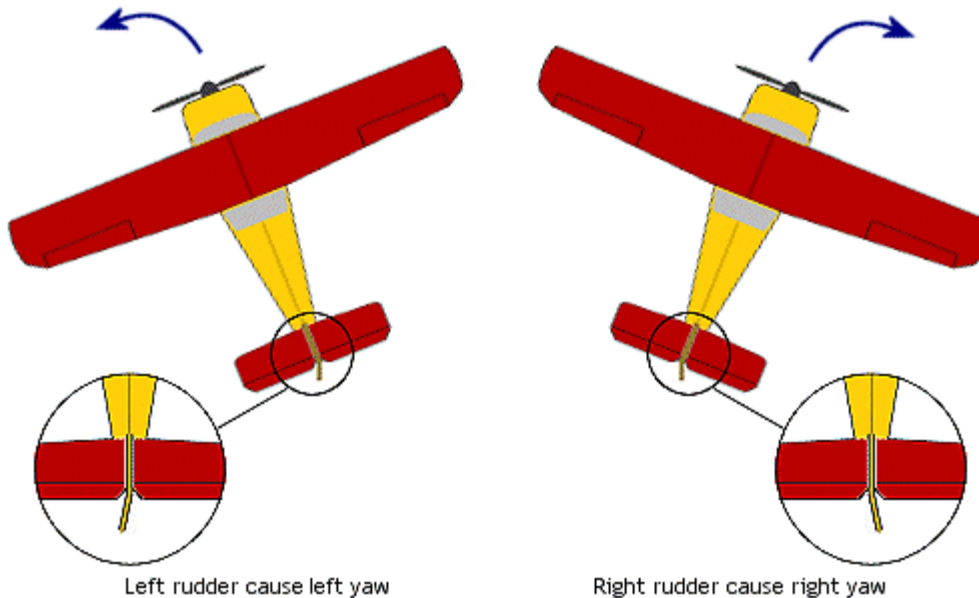



# Landing Gear

- Two main wheels and a third wheel at the front or rear
- Parking, Taxiing, Take off, Landing

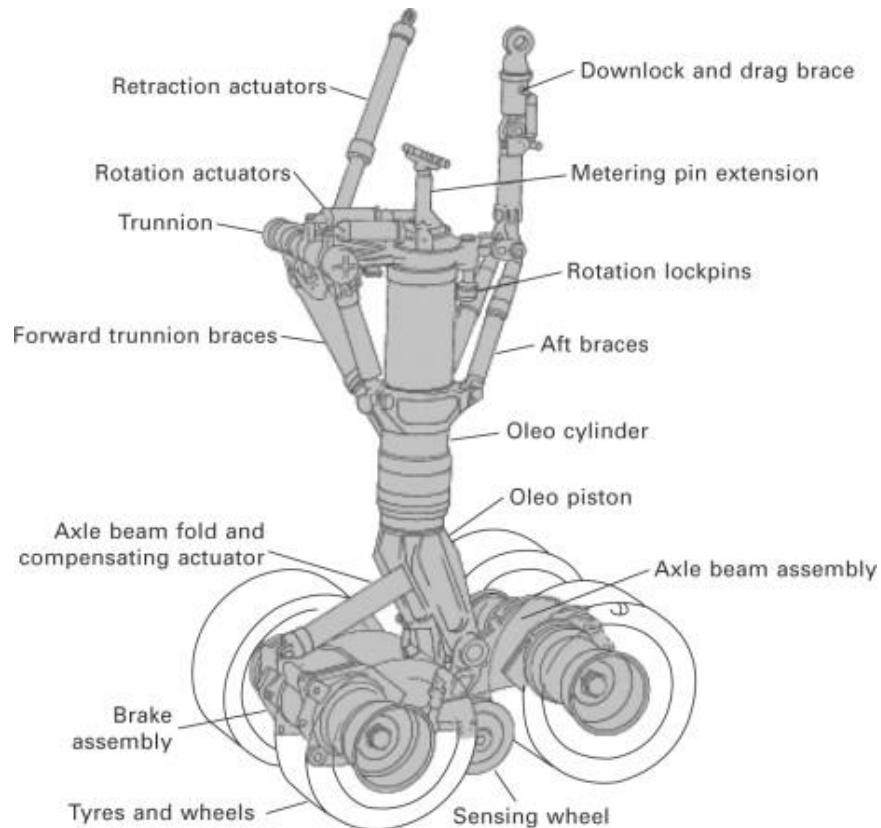

# Power Plant

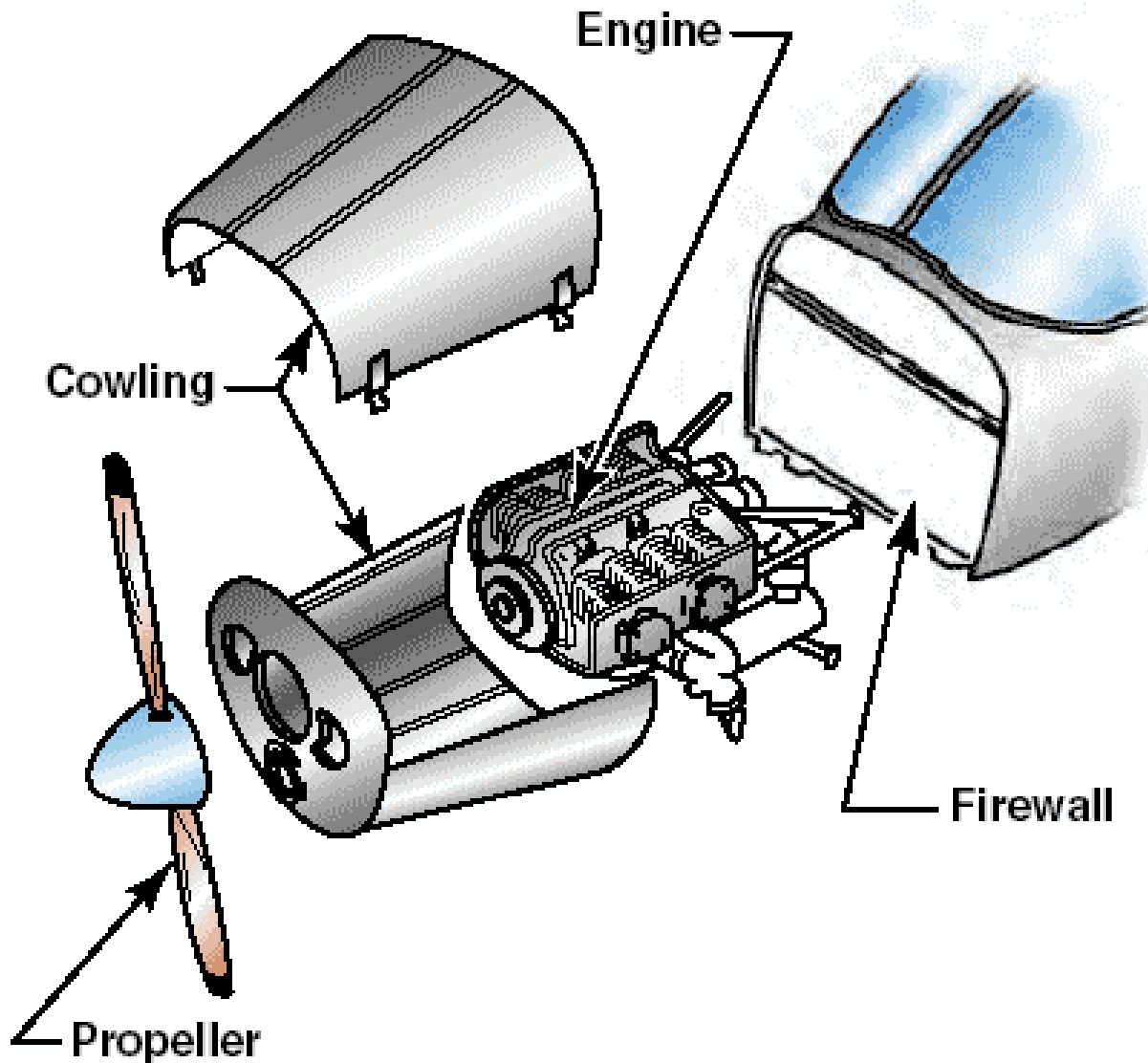

# AIR CRAFT ENGINES

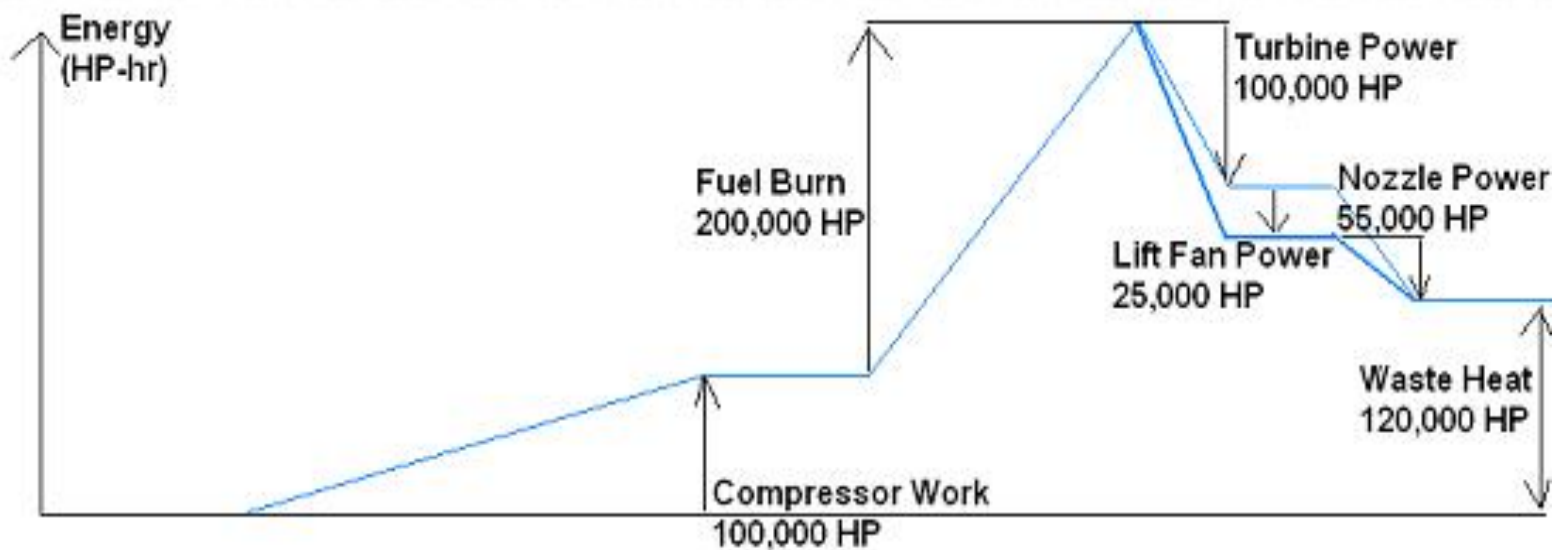
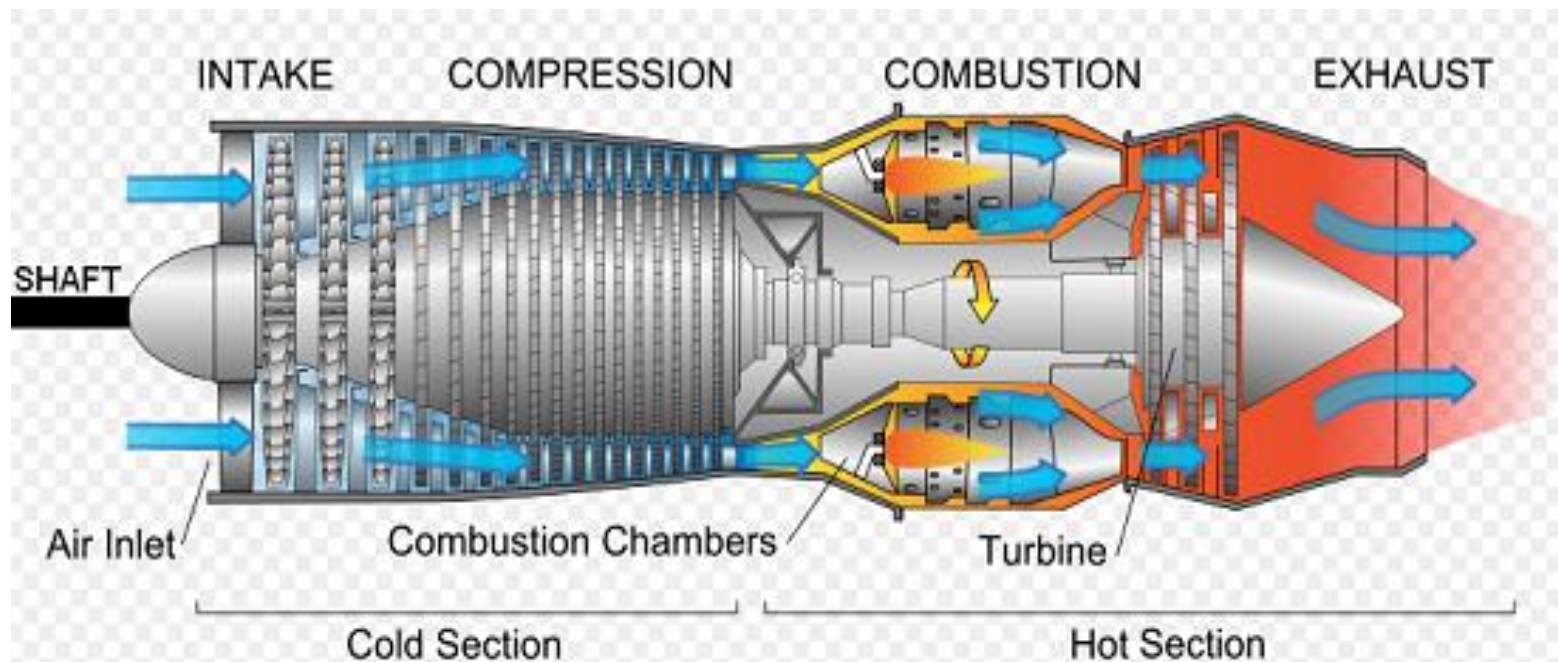

# Power Plant (Types)

- Pistonprop
- Turboprop
- Turbojet
- Turbofan
- Ramjet

# Turbo Jet Engine

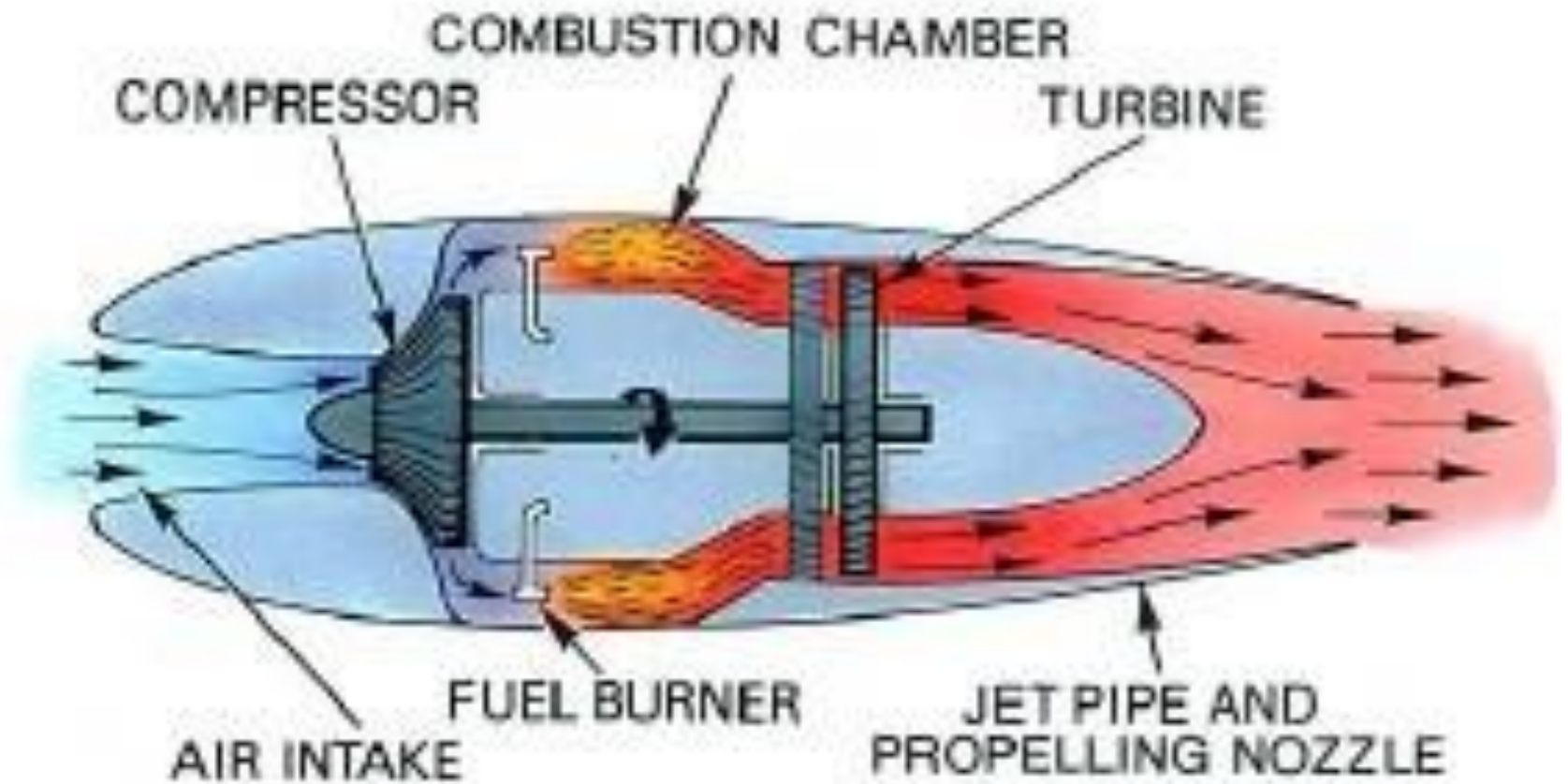

# Ram Jet Engine

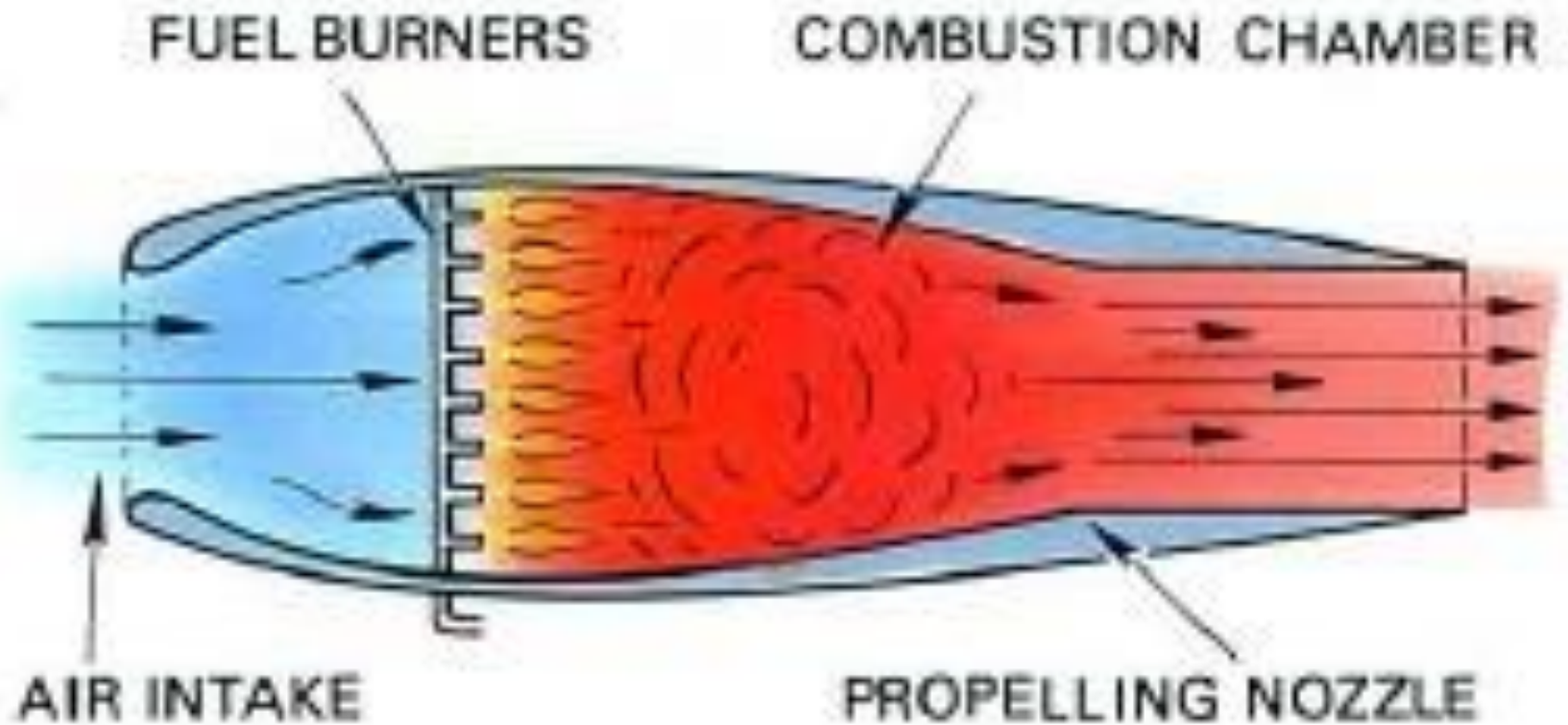

# Lift, Thrust, Weight, and Drag

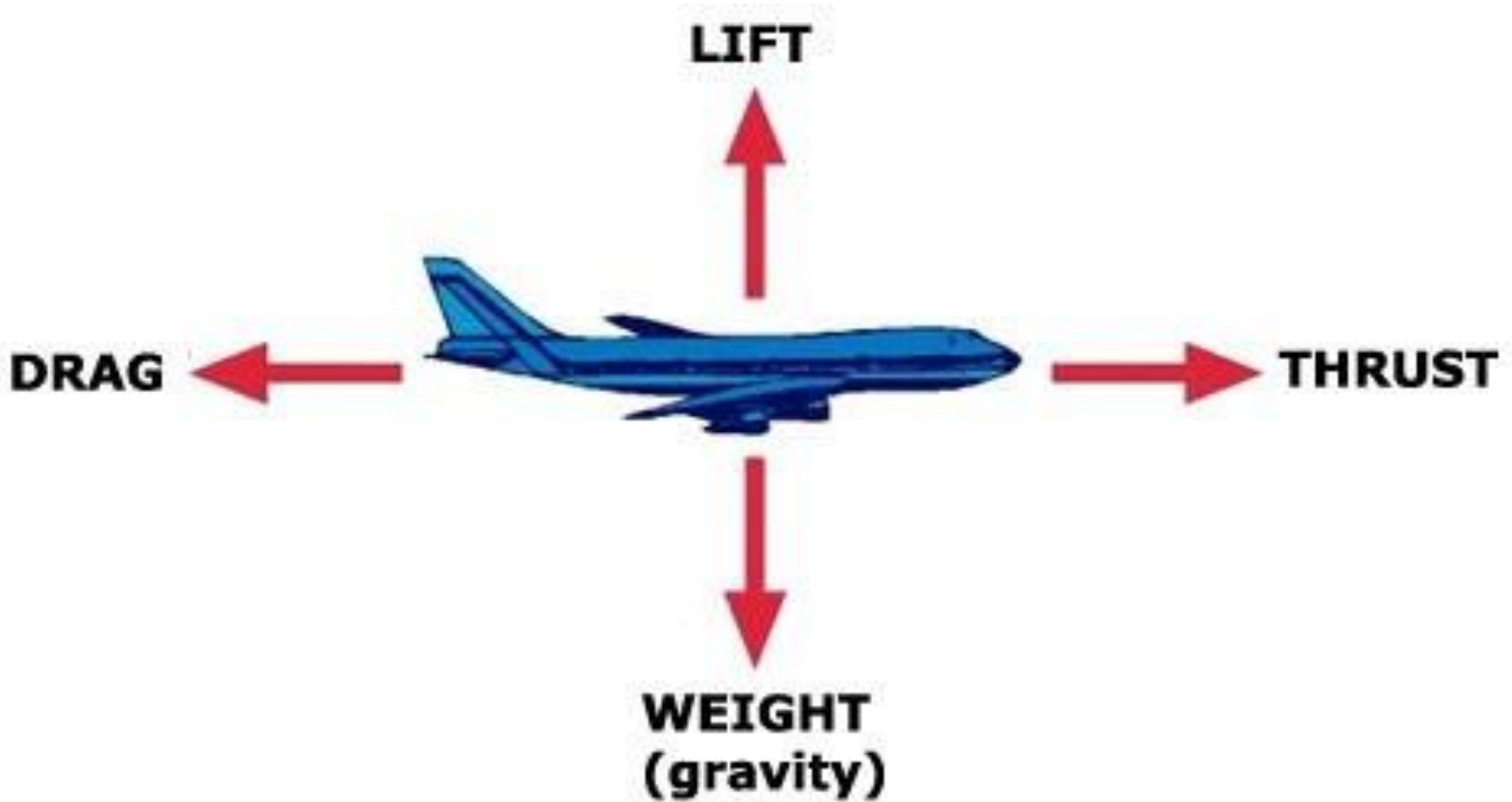

# Bernoulli's Equation

$$\int \frac{dp}{\rho} + \frac{1}{2} v^2 + gz = \text{constant}$$

First term is the internal energy of unit mass of the air,  $\frac{1}{2} v^2$  is the kinetic energy of unit mass and  $gz$  is the potential energy of unit mass. Thus, Bernoulli's equation in this form is a statement of the principle of conservation of energy in the absence of heat exchanged and work done.

$$p + \frac{1}{2} \rho v^2 + \rho gz = \text{constant}$$

This is *Bernoulli's equation for an incompressible fluid, i.e. a fluid that cannot be compressed or expanded, and for which the density is invariable.*



# Aerofoil (Wing) Section

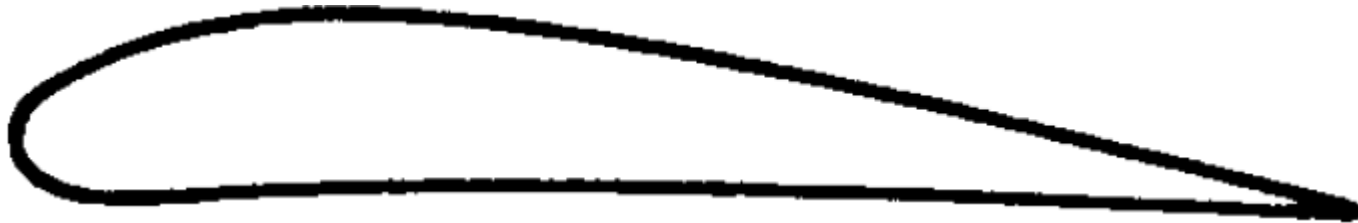

# Air flow over an aerofoil inclined at a small angle

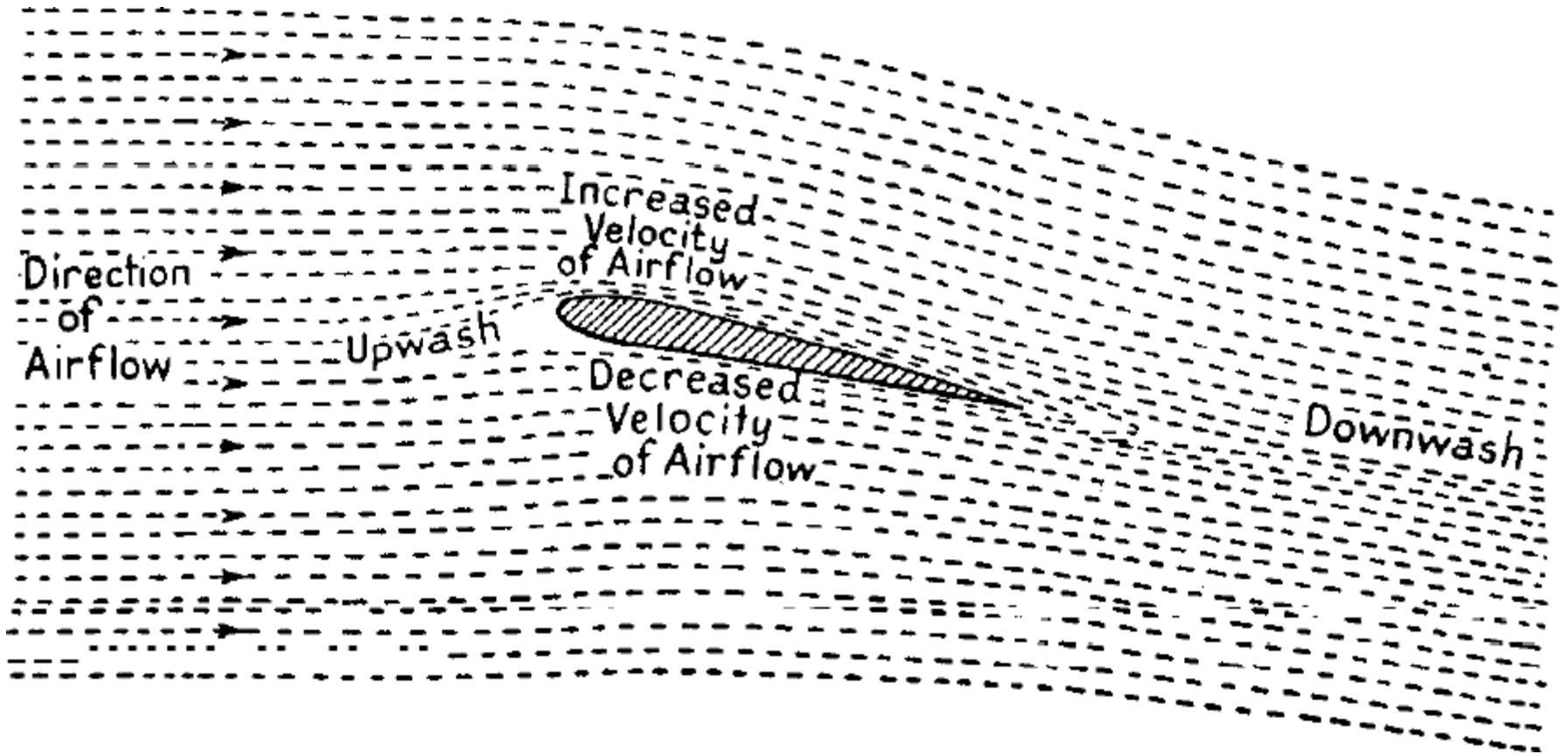

# Pressure Distribution over Aerofoil

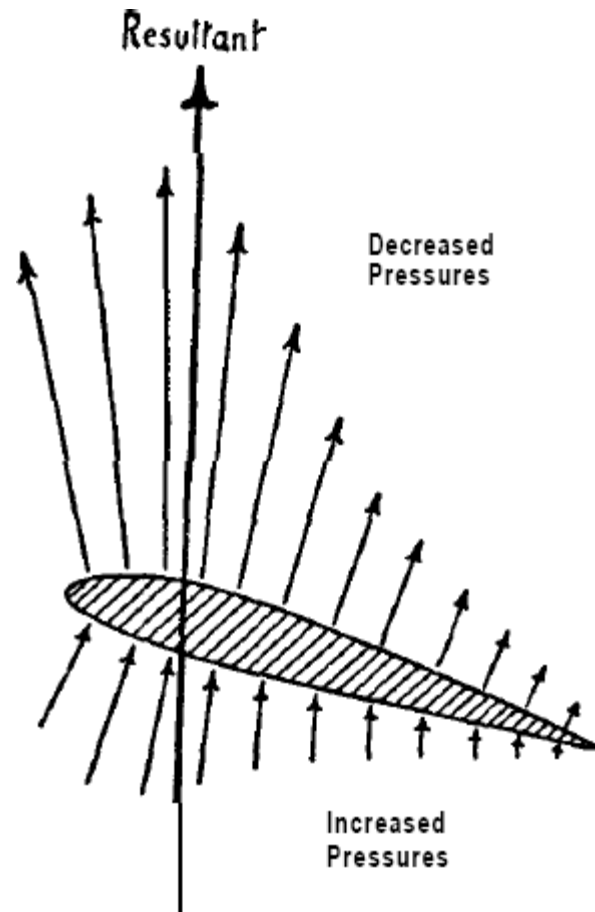

# Lift Produced

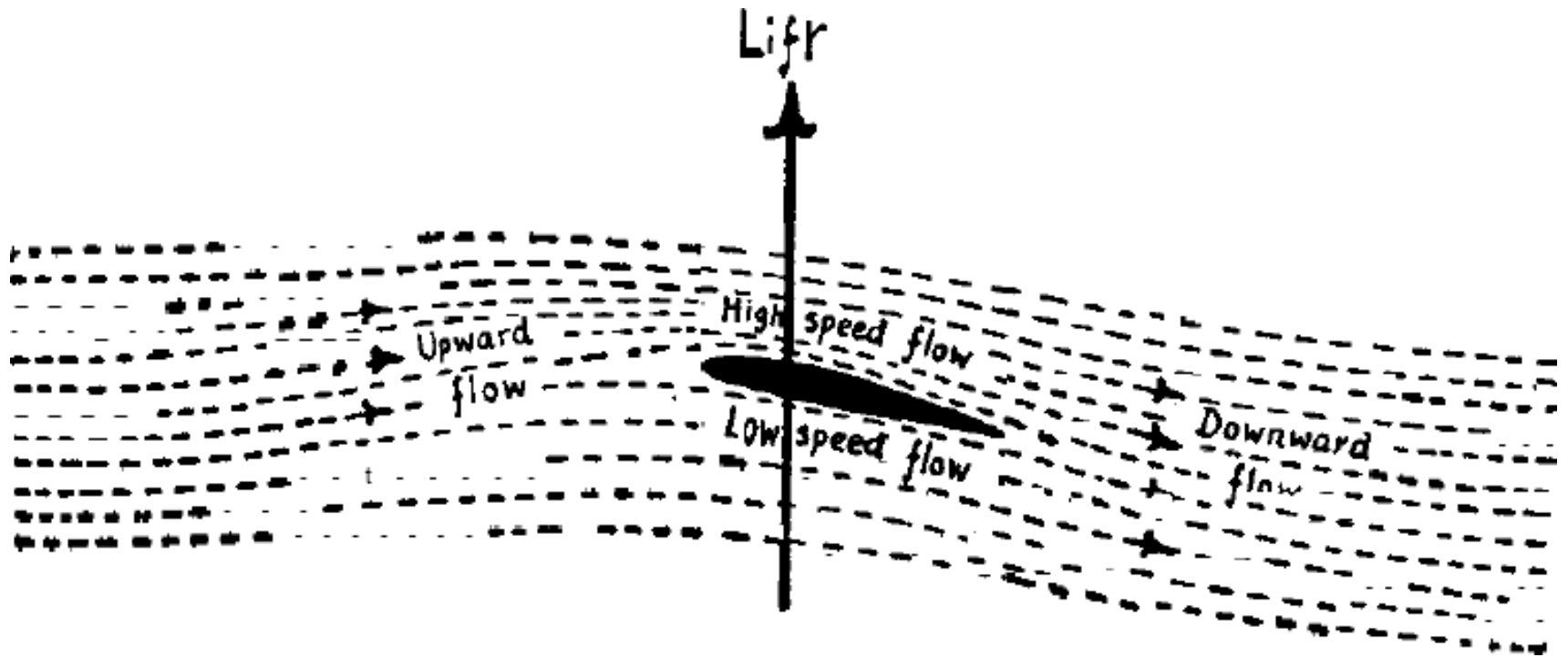

**THANKS**