



Designation: C140/C140M – 18

# Standard Test Methods for Sampling and Testing Concrete Masonry Units and Related Units<sup>1</sup>

This standard is issued under the fixed designation C140/C140M; the number immediately following the designation indicates the year of original adoption or, in the case of revision, the year of last revision. A number in parentheses indicates the year of last reapproval. A superscript epsilon ( $\epsilon$ ) indicates an editorial change since the last revision or reapproval.

*This standard has been approved for use by agencies of the U.S. Department of Defense.*

## 1. Scope\*

1.1 These test methods provide various testing procedures commonly used for evaluating characteristics of concrete masonry units and related concrete units. Methods are provided for sampling, measurement of dimensions, compressive strength, absorption, unit weight (density), moisture content, flexural load, and ballast weight. Not all methods are applicable to all unit types, however.

1.2 Specific testing and reporting procedures are included in annexes to these test methods for the following specific unit types:

**Annex A1**—Concrete masonry units (Specifications **C90**, **C129**)

**Annex A2**—Concrete and calcium silicate brick (Specifications **C55**, **C73**, **C1634**)

**Annex A3**—Segmental retaining wall units (Specification **C1372**)

**Annex A4**—Concrete interlocking paving units (Specification **C936/C936M**)

**Annex A5**—Concrete grid paving units (Specification **C1319**)

**Annex A6**—Concrete roof pavers (Specification **C1491**)

**Annex A7**—Dry-cast articulating concrete block (Specification **D6684**)

1.3 The test procedures included in these test methods are also applicable to other types of units not referenced in these test methods, but specific testing and reporting requirements for those units are not included.

1.4 These test methods include the following sections:

	Section
Scope	1
Referenced Documents	2
Terminology	3
Significance and Use	4
Sampling	5
Measurement of Dimensions	6
Compressive Strength	7

<sup>1</sup> These test methods are under the jurisdiction of ASTM Committee **C15** on Manufactured Masonry Units and are the direct responsibility of Subcommittee **C15.03** on Concrete Masonry Units and Related Units.

Current edition approved July 15, 2018. Published August 2018. Originally approved in 1938. Last previous edition approved in 2017 as C140 – 17b. DOI: 10.1520/C0140\_C0140M-18.

Absorption	Section 8
Calculations	9
Report	10
Keywords	11
Annexes—Test Procedures	
Concrete Masonry Units	Annex A1
Concrete and Calcium Silicate Brick	Annex A2
Segmental Retaining Wall Units	Annex A3
Concrete Interlocking Paving Units	Annex A4
Concrete Grid Paving Units	Annex A5
Concrete Roof Pavers	Annex A6
Dry-Cast Articulating Concrete Block	Annex A7
Worksheet and Test Report for Concrete Masonry Units	Appendix X1

NOTE 1—The testing laboratory performing these test methods should be evaluated in accordance with Practice **C1093**.

1.5 The text of this test method references notes and footnotes that provide explanatory material. These notes and footnotes (excluding those in tables and figures) shall not be considered as requirements of the standard.

1.6 The values stated in either SI units or inch-pound units are to be regarded separately as standard. The values stated in each system may not be exact equivalents; therefore, each system shall be used independently of the other. Combining values from the two systems may result in non-conformance with the standard.

1.7 *This standard does not purport to address all of the safety concerns, if any, associated with its use. It is the responsibility of the user of this standard to establish appropriate safety, health, and environmental practices and determine the applicability of regulatory limitations prior to use.*

1.8 *This international standard was developed in accordance with internationally recognized principles on standardization established in the Decision on Principles for the Development of International Standards, Guides and Recommendations issued by the World Trade Organization Technical Barriers to Trade (TBT) Committee.*

\*A Summary of Changes section appears at the end of this standard

## 2. Referenced Documents

### 2.1 *ASTM Standards*:<sup>2</sup>

- C55 Specification for Concrete Building Brick
- C73 Specification for Calcium Silicate Brick (Sand-Lime Brick)
- C90 Specification for Loadbearing Concrete Masonry Units
- C129 Specification for Nonloadbearing Concrete Masonry Units
- C143/C143M Test Method for Slump of Hydraulic-Cement Concrete
- C936/C936M Specification for Solid Concrete Interlocking Paving Units
- C1093 Practice for Accreditation of Testing Agencies for Masonry
- C1232 Terminology for Masonry
- C1319 Specification for Concrete Grid Paving Units
- C1372 Specification for Dry-Cast Segmental Retaining Wall Units
- C1491 Specification for Concrete Roof Pavers
- C1552 Practice for Capping Concrete Masonry Units, Related Units and Masonry Prisms for Compression Testing
- C1634 Specification for Concrete Facing Brick
- C1716 Specification for Compression Testing Machine Requirements for Concrete Masonry Units, Related Units, and Prisms
- D6684 Specification for Materials and Manufacture of Articulating Concrete Block (ACB) Revetment Systems
- E4 Practices for Force Verification of Testing Machines
- E6 Terminology Relating to Methods of Mechanical Testing

### 2.2 *Other Documents*:

- SP 960-12 NIST Recommended Practice Guide – Stopwatch and Timer Calibration<sup>3</sup>

## 3. Terminology

3.1 Terminology defined in Terminologies C1232 and E6 shall apply for these test methods.

### 3.2 *Definitions of Terms Specific to This Standard*:

3.2.1 *lot, n*—any number of concrete masonry units or related units, designated by the producer, of any configuration or dimension manufactured by the producer using the same materials, concrete mix design, manufacturing process, and curing method.

## 4. Significance and Use

4.1 These test methods provide general testing requirements for application to a broad range of concrete products. Those general testing requirements are included in the body of this standard.

NOTE 2—Consult manufacturer, supplier, product specifications, or other resources for more specific measurement or testing guidelines for those products not addressed with the annex of this standard.

<sup>2</sup> For referenced ASTM standards, visit the ASTM website, [www.astm.org](http://www.astm.org), or contact ASTM Customer Service at [service@astm.org](mailto:service@astm.org). For *Annual Book of ASTM Standards* volume information, refer to the standard's Document Summary page on the ASTM website.

<sup>3</sup> Available at <http://tf.nist.gov/general/pdf/2281.pdf>

4.2 These test methods provide specific testing requirements in two distinct sections, the requirements applicable to all units covered by these test methods and those applicable to the specific unit types. The requirements applicable to all units are included in the body of these test methods and those applicable to the specific unit types are included within the annexes.

## 5. Sampling

### 5.1 *Selection of Test Specimens*:

5.1.1 For purposes of testing, full-sized units shall be selected by the purchaser or authorized representative. The selected specimens shall be of similar configuration and dimensions. Specimens shall be representative of the whole lot of units from which they are selected.

### 5.2 *Number of Specimens*:

5.2.1 Unless specified otherwise in the applicable annex, a set of units shall consist of six full-size units.

5.3 Remove loose material from the specimens (including the cores) prior to determining the received weight.

NOTE 3—An abrasive stone or wire brush is typically used to remove loose material.

5.4 *Identification*—Mark each specimen so that it may be identified at any time. Markings shall cover not more than 5 % of the surface area of the specimen.

5.5 *Received Weight*—Weigh each specimen immediately after sampling and marking, and record as  $w_r$  (received weight). Record time and place  $w_r$  was measured.

NOTE 4—Received weights often have direct relationships with other unit properties and are therefore a useful method of evaluating results or for sorting purposes. The weight of a concrete masonry unit and related unit changes with time and exposure conditions, primarily as a result of the moisture within the unit. Therefore, to understand the context of a received weight value, it is also important to understand the point in time and the frame of reference when that weight was determined. “Time and place” should not refer to when and where the unit was sampled but when and where the received weights were determined. In addition to date and time references, it is also important to know if those weights were determined after units reached equilibrium with lab environment, or before units were shipped, or after delivery to the job site, and so forth.

## 6. Measurement of Dimensions

### 6.1 *Apparatus*:

6.1.1 *Measurement Devices*—Devices used to measure specimen dimensions shall have divisions not greater than 0.1 in. [2.5 mm] when the dimension is to be reported to the nearest 0.1 in. [2.5 mm] and not greater than 0.01 in. [0.25 mm] when the dimension is to be reported to the nearest 0.01 in. [0.25 mm].

6.1.2 Measuring devices shall be readable and accurate to the division required to be reported. Accuracy shall be verified at least once annually. Verification record shall include date of verification, person or agency performing verification, identification of reference standard used, test points used during verification, and readings at test points.

6.2 *Specimens*—Three full-size units shall be selected for measurement of dimensions.

6.3 *Measurements*—Measure specimens in accordance with the applicable annex of this standard. For those products not

covered by the annexes of this standard, measure overall dimensions (width, height, length) in at least two locations on opposite sides of the specimen to the nearest division required to be reported. Document location of each measurement on a sketch or photograph of the specimen.

NOTE 5—Specimens used for measurement of dimensions may be used in other tests.

NOTE 6—Calipers, micrometers, and steel scales and dividers of the appropriate accuracy and readability have been shown to be adequate for these measurements.

## 7. Compressive Strength

7.1 *Test Apparatus*—The compressive strength testing machine shall conform to Specification C1716.

NOTE 7—Previous versions of this standard have contained specific requirements for compressive strength test machines. These requirements have been replaced with reference to Specification C1716.

### 7.2 Test Specimens:

7.2.1 Unless specified otherwise in the applicable annex, test three specimens in compression.

7.2.2 Unless specified otherwise in the applicable annex, specimens shall be full-sized units except when the units cannot be tested full-size due to specimen configuration or testing machine requirements. In these cases, reduce the specimen size in accordance with Annex A1.

7.2.3 After delivery to the laboratory, store compression specimens (unstacked and separated by not less than 0.5 in. [13 mm] on all sides) continuously in air at a temperature of  $75 \pm 15^\circ\text{F}$  [ $24 \pm 8^\circ\text{C}$ ] and a relative humidity of less than 80 % for not less than 48 h. Alternatively, if compression results are required sooner, store units unstacked in the same environment described above with a current of air from an electric fan passing over them for a period of not less than 4 h. Continue passing air over the specimens until two successive weighings at intervals of 2 h show an increment of loss not greater than 0.2 % of the previously determined weight of the specimen and until no moisture or dampness is visible on any surface of the unit. Specimens shall not be subjected to oven-drying.

NOTE 8—In this test method, net area (other than certain solid units, see 9.5) is determined from specimens other than those subjected to compression testing. The compressive strength method is based on the assumption that units used for determining net volume (absorption specimens) have the same net volume as units used for compression testing. Sampled split face units, which have irregular surfaces, should be divided at the time they are sampled from the lot, such that the absorption test specimens have a net volume that is visually representative and a weight that is representative of the compression test specimens.

7.2.4 Where saw-cutting of test specimens is allowed or required by the standard or applicable annex, sawing shall be performed in an accurate, competent manner, subjecting the specimen to as little saw vibration as possible. Use a diamond saw blade of proper hardness. Following cutting, residue from the cutting operation shall be removed prior to continuing testing (see Note 9). If the specimen is wetted during sawing, allow the specimen to dry to equilibrium with laboratory air conditions before testing, using the procedures outlined in 7.2.3.

NOTE 9—For specimens cut with a wet saw, rinsing with clean water is

typically sufficient for removing cutting residue. For specimens cut with a dry saw, brushing with a soft-bristle brush is typically sufficient for removing cutting residue.

7.2.5 If compression test specimens have been saw-cut from full-sized units and the net area of the compression test specimens can not be determined by 9.5.1, saw-cut an additional three units to the dimensions and configuration of the three compression test specimens. The average net area for the saw-cut compression specimens shall be taken as the average net area of the additional three saw-cut units calculated as required in 9.5. Calculated net volumes of saw-cut specimens shall not be used in calculating equivalent thickness.

7.3 *Capping*—Cap test specimens in accordance with Practice C1552.

### 7.4 Compression Testing Procedure:

7.4.1 *Position of Specimens*—Test specimens with the centroid of their bearing surfaces aligned vertically with the center of thrust of the spherically seated steel bearing block of the testing machine (Note 10). Except for special units intended for use with their cores in a horizontal direction, test all hollow concrete masonry units with their cores in a vertical direction. Test masonry units that are 100 % solid and special hollow units intended for use with their hollow cores in a horizontal direction in the same direction as in service. Prior to testing each unit, ensure that the upper platen moves freely within its spherical seat to attain uniform seating during testing.

NOTE 10—For those masonry units that are symmetrical about an axis, the location of that axis can be determined geometrically by dividing the dimension perpendicular to that axis (but in the same plane) by two. For those masonry units that are nonsymmetrical about an axis, the location of that axis can be determined by balancing the masonry unit on a knife edge or a metal rod placed parallel to that axis. If a metal rod is used, the rod shall be straight, cylindrical (able to roll freely on a flat surface), have a diameter of not less than 0.25 in. [6 mm] and not more than 0.75 in. [19 mm], and its length shall be sufficient to extend past each end of the specimen when placed upon it. The metal rod shall be placed on a smooth, flat, level surface. Once determined, the centroidal axis shall be marked on the end of the unit using a pencil or marker having a marking width of not greater than 0.05 in. [1.5 mm]. A tamping rod used for consolidation of concrete and grout for slump tests performed in accordance with Test Method C143/C143M is often used as a balancing rod.

7.4.2 *Moisture Condition of Specimens*—At the time the specimens are tested, they shall be free of visible moisture or dampness.

7.4.3 *Speed of Testing*—Apply the load (up to one half of the expected maximum load) at any convenient rate, after which adjust the controls of the machine as required to give a uniform rate of travel of the moving head such that the remaining load is applied in not less than 1 nor more than 2 min. The results of the first specimen shall not be discarded so long as the actual loading time for the second half of the actual load is greater than 30 s.

NOTE 11—The allowance for a loading rate outside of 1 to 2 min for the first specimen acknowledges that the expected load may be different than the actual maximum load. The load rate for the remaining two specimens should be adjusted based on the first specimen results.

7.4.4 *Maximum Load*—Record the maximum compressive load in pounds [newtons] as  $P_{max}$ .



## 8. Absorption

8.1 *Apparatus*—Unless specified otherwise in the appropriate annex, the following equipment shall be used:

8.1.1 *Balance*—A balance readable and accurate to 0.1 % of the weight of the smallest specimen tested. Balances shall be calibrated in accordance with Practice C1093.

8.1.2 *Oven*—A ventilated oven of appropriate size capable of maintaining a uniform temperature of  $230 \pm 9^\circ\text{F}$  [ $110 \pm 5^\circ\text{C}$ ]. Ovens shall be verified in accordance with Practice C1093.

8.1.3 *Timer*—A timer readable and accurate to 1 second. Timers shall be verified in accordance with Practice C1093. (See Note 12.)

NOTE 12—Recommended procedures for verifying timers can be found in NIST Special Publication 960-12 (2009): NIST Recommended Practice Guide—Stopwatch and Timer Calibrations.

### 8.2 Test Specimens:

8.2.1 Unless specified otherwise in the applicable annex, test three specimens in absorption.

8.2.2 Unless specified otherwise in the applicable annex, tests shall be performed on full-sized units or specimens saw-cut from full-sized units. Calculated values for absorption and density of reduced-size absorption specimens shall be considered as representative of the whole unit.

8.2.2.1 When test specimens are saw-cut from full-sized units, the test specimen shall have an initial weight after cutting of no less than 20 % of the initial received weight of the full-sized unit.

NOTE 13—When performing absorption tests on reduced-sized specimens, it is preferable to have a test specimen that is as large as practically possible and can be accommodated by laboratory equipment. This helps to reduce any location-specific variability from the absorption results.

### 8.3 Procedure:

8.3.1 Immerse the test specimens in water at a temperature of 60 to 80°F [15 to 27°C] for 24 to 28 h such that the top surfaces of the specimens are at least 6 in. [150 mm] below the surface of the water. Specimens shall be separated from each other and from the bottom of the immersion tank by at least 0.125 in. [3 mm], using wire mesh, grating, or other spacers. The spacer shall not cover more than 10 % of the area of the face that is in direct contact with the spacer (see Note 14).

NOTE 14—The intent of the requirement for spacer contact with the specimen surface is to limit the possibility of reduced absorption of water due to blockage by the spacer. In order to determine compliance, only the area of the surface of the specimen in contact with the spacer should be considered. For example, when a spacer is used between the bottom of the specimen and the bottom of the tank, only the area of the bottom of the unit should be used to determine the 10 % limit (not the surface area of the entire specimen).

8.3.2 Weigh the specimens while suspended by a metal wire and completely submerged in water and record  $w_i$  (immersed weight).

8.3.3 Remove the specimens from water and allow to drain by placing them on a 0.375-in. [10-mm] or coarser wire mesh. While the specimen is draining and before weighing, remove visible surface water with a damp cloth. Weigh specimens  $60 \pm 5$  s following removal from water. Record as  $w_s$  (saturated weight).

8.3.4 Subsequent to saturation, dry all specimens in a ventilated oven at  $230 \pm 9^\circ\text{F}$  [ $110 \pm 5^\circ\text{C}$ ] for not less than 24 h and until two successive weighings at intervals of 2 h show an increment of loss not greater than 0.2 % of the last previously determined weight of the specimen. Record weight of dried specimens as  $w_d$  (oven-dry weight).

## 9. Calculations

9.1 *Absorption*—Calculate absorption as follows:

$$\text{Absorption, lb/ft}^3 = [(w_s - w_d)/(w_s - w_i)] \times 62.4 \quad (1)$$

$$[\text{Absorption, kg/m}^3 = [(w_s - w_d)/(w_s - w_i)] \times 1000]$$

$$\text{Absorption, \%} = [(w_s - w_d)/w_d] \times 100$$

where:

$w_s$  = saturated weight of specimen, lb [kg],  
 $w_i$  = immersed weight of specimen, lb [kg], and  
 $w_d$  = oven-dry weight of specimen, lb [kg].

9.2 *Moisture Content*—Calculate the moisture content of the unit at the time it is sampled (when  $w_r$  is measured) as follows:

Moisture Content, % of total absorption =

$$[(w_r - w_d)/(w_s - w_d)] \times 100 \quad (2)$$

where:

$w_r$  = received weight of unit, lb [kg],  
 $w_d$  = oven-dry weight of unit, lb [kg], and  
 $w_s$  = saturated weight of unit, lb [kg].

NOTE 15—When determining the moisture content of a unit or set of units, the value determined is a measure of the water content of a unit based upon the received weight of the unit  $w_r$ . Thus, the moisture content calculation above is only applicable to the unit moisture content at the time the received weight,  $w_r$ , is obtained.

9.3 *Density*—Calculate oven-dry density as follows:

$$\text{Density (D), lb/ft}^3 = [w_d / (w_s - w_i)] \times 62.4 \quad (3)$$

$$[\text{Density (D), kg/m}^3 = [w_d / (w_s - w_i)] \times 1000]$$

where:

$w_d$  = oven-dry weight of specimen, lb [kg],  
 $w_s$  = saturated weight of specimen, lb [kg], and  
 $w_i$  = immersed weight of specimen, lb [kg].

9.4 *Net Volume*—Calculate net volume as follows:

$$\text{Net Volume (} V_n \text{), ft}^3 = w_d / D = (w_s - w_i) / 62.4 \quad (4)$$

$$[\text{Net Volume (} V_n \text{), cm}^3 = (w_d / D) \times 10^6 = (w_s - w_i) \times 10^3]$$

where:

$V_n$  = net volume of specimen, ft<sup>3</sup> [cm<sup>3</sup>],  
 $w_d$  = oven-dry weight of specimen, lb [kg],  
 $D$  = oven-dry density of specimen, lb/ft<sup>3</sup> [kg/m<sup>3</sup>],  
 $w_s$  = saturated weight of specimen, lb [kg], and  
 $w_i$  = immersed weight of specimen, lb [kg].

9.5 *Average Net Area*—Calculate net area as follows:

$$\text{Average Net Area (} A_n \text{), in.}^2 = (V_n \times 1728) / H \quad (5)$$

$$[\text{Average Net Area (} A_n \text{), mm}^2 = (V_n \times 10^3) / H]$$

where:

$V_n$  = net volume of specimen, ft<sup>3</sup> [cm<sup>3</sup>],

$A_n$  = average net area of specimen, in.<sup>2</sup> [mm<sup>2</sup>], and  
 $H$  = average height of specimen, in. [mm].

NOTE 16—In SI units, net volume is calculated in terms of cubic centimetres to be consistent with the reporting requirements of this standard. Net area, however, is calculated in terms of square millimetres in order to facilitate calculation of compressive strength in MPa which is defined as N/mm<sup>2</sup>.

9.5.1 Except for irregularly shaped specimens, such as those with split surfaces, calculate the net area of coupons and those specimens whose net cross-sectional area in every plane parallel to the bearing surface is equal to the gross cross-sectional area measured in the same plane, as follows:

$$\text{Net Area } (A_n), \text{ in.}^2 [\text{mm}^2] = L \times W \quad (6)$$

where:

$A_n$  = net area of coupon or specimen, in.<sup>2</sup> [mm<sup>2</sup>],  
 $L$  = average length of coupon or specimen, in. [mm], and  
 $W$  = average width of coupon or specimen, in. [mm].

9.6 *Gross Area*—Calculate gross area of each specimen as follows:

$$\text{Gross Area } (A_g), \text{ in.}^2 [\text{mm}^2] = L \times W \quad (7)$$

where:

$A_g$  = gross area of specimen, in.<sup>2</sup> [mm<sup>2</sup>],  
 $L$  = average length of specimen, in. [mm], and  
 $W$  = average width of specimen, in. [mm].

9.6.1 The gross cross-sectional area of a specimen is the total area of a section perpendicular to the direction of the load, including areas within cells and reentrant spaces, unless these spaces are to be occupied in the masonry by portions of adjacent masonry.

### 9.7 *Compressive Strength*:

9.7.1 *Net Area Compressive Strength*—Calculate the net area compressive strength of the specimen as follows:

$$\text{Net Area Compressive Strength, psi [MPa]} = P_{max}/A_n \quad (8)$$

where:

$P_{max}$  = maximum compressive load, lb [N], and  
 $A_{n, avg}$  = average of the net area values determined for each of the three absorption specimens, in.<sup>2</sup> [mm<sup>2</sup>].

9.7.2 *Gross Area Compressive Strength*—Calculate the gross area compressive strength of the specimen as follows:

$$\text{Gross Area Compressive Strength, psi [MPa]} = P_{max}/A_g \quad (9)$$

where:

$P_{max}$  = maximum compressive load, lb [N], and  
 $A_{g, avg}$  = average of the gross area values determined for each of the three specimens, in.<sup>2</sup> [mm<sup>2</sup>].

## 10. Report

10.1 For the purpose of reporting test results, all observed or calculated values shall be rounded using the following procedure:

10.1.1 When the digit immediately after the last place to be retained is less than 5, retain unchanged the digit in the last place retained.

10.1.2 When the digit immediately after the last place to be retained is greater than or equal to 5, increase by 1 the digit in the last place retained.

NOTE 17—As an example, density results are required to be reported to the nearest 0.1 lb/ft<sup>3</sup> [1 kg/m<sup>3</sup>] in 10.3.7. For inch-pound units, a calculated value of 130.85 lb/ft<sup>3</sup> should be reported as 130.9 lb/ft<sup>3</sup>. For SI units, a calculated value of 2095.85 kg/m<sup>3</sup> should be reported as 2096 kg/m<sup>3</sup>.

10.2 A complete report shall include the following general information:

- 10.2.1 Name and address of the testing laboratory,
- 10.2.2 Identification of the report and the date of issue,
- 10.2.3 Name and address of the client or the identification of the project,
- 10.2.4 Description and identification of the test sample,
- 10.2.5 Date of receipt of the test sample,
- 10.2.6 Date(s) of test performance,
- 10.2.7 Identification of the standard test method used, including edition, and a notation of any known deviation from the test method,
- 10.2.8 Name of the person(s) accepting technical responsibility for the test report,
- 10.2.9 Age of test specimens, if known,
- 10.2.10 Identification of any test results obtained from another laboratory, and
- 10.2.11 A photograph, sketch, or description of the configuration of the unit.

10.3 Unless specified otherwise in the applicable annex, a complete report shall include the following test results for the tests performed:

10.3.1 The average width, height and length to the nearest 0.1 in. [2.5 mm] separately for each specimen and as the average for the three specimens tested.

10.3.2 The net area to the nearest 0.1 in.<sup>2</sup> [50 mm<sup>2</sup>] separately for each specimen and as the average for the three specimens tested.

10.3.3 The maximum load separately for each specimen and as the average for the three specimens tested. Record the load as indicated to the nearest 10 lb [50 N] or the minimum resolution of the test machine as used during testing, whichever is greater.

10.3.4 The net area compressive strength to the nearest 10 psi [0.1 MPa] separately for each specimen and as the average for the three specimens tested.

10.3.5 The immersed, saturated, and oven dry weights ( $w_i$ ,  $w_s$ , and  $w_d$ ) to the nearest 0.1 lb [0.05 kg] separately for each specimen and as the average for the three specimens tested.

10.3.6 The absorption to the nearest 0.1 lb/ft<sup>3</sup> [1 kg/m<sup>3</sup>] separately for each specimen and as the average for the three specimens tested.

10.3.7 The density to the nearest 0.1 lb/ft<sup>3</sup> [1 kg/m<sup>3</sup>] separately for each specimen and as the average for the three specimens tested.

10.3.8 When required, the received weight ( $w_r$ ) to the nearest 0.1 lb [0.05 kg] and the moisture content to the nearest 0.1 % separately for each specimen and as the average for the three specimens tested. The time when the moisture content is determined (when  $w_r$  is measured) shall also be reported.

10.3.9 The size and configuration of the specimens tested for compressive strength and absorption.

10.4 Provide a summary report that includes the information necessary to determine compliance with the applicable product specification for the properties evaluated.

10.5 A complete report shall also include the other reporting requirements from the applicable annex.

NOTE 18—This summary report can be included as part of the test report or provided separately as a cover letter. See Appendix X1 for an example of a test report with summary section for concrete masonry units.

11. Keywords

11.1 absorption; compressive strength; concrete masonry units; density; equivalent thickness; face shell; moisture content; roof paver; web area; webs; web thickness

ANNEXES

(Mandatory Information)

A1. TEST PROCEDURES FOR CONCRETE MASONRY UNITS

A1.1 Scope

A1.1.1 This annex includes testing requirements that are particular for concrete masonry units that are manufactured for compliance with the following unit specifications: C90, C129.

A1.2 Measurement

A1.2.1 For each unit, measure and record the following to the nearest division required to be reported (see Fig. A1.1):

- (1) Width ( $W$ ) at mid-length across the top and bottom bearing surfaces. Average the two recorded values to determine the width of the specimen.
- (2) Height ( $H$ ) at mid-length on each face. Average the two recorded values to determine the height of the specimen.
- (3) Length ( $L$ ) at mid-height on each face. Average the two recorded values to determine the length of the specimen.

A1.2.2 For each unit, measure the face shell thicknesses ( $t_{fs}$ ) at the thinnest point 0.50 in. [13 mm] down from the top surface of the unit as manufactured (typically the bottom surface of the unit as laid) and record to the nearest division required to be reported. Disregard grooves, scores, and similar details in the face shell thickness measurements.

A1.2.3 For each unit, when the thinnest point of opposite face shells differ in thickness by less than 0.125 in. [3 mm],

calculate the minimum face shell thickness by averaging the recorded measurements. When the thinnest points differ by more than 0.125 in. [3 mm], the minimum face shell thickness shall be taken as the smaller of the two recorded measurements.

A1.2.4 For each unit, measure the web thickness ( $t_w$ ) at the minimum thickness of each web to the nearest 0.01 in. [0.25 mm].

A1.2.5 For each unit, determine the minimum web area using one of the following methods:

A1.2.5.1 For units with rectangular webs, measure the web height ( $t_h$ ) at the minimum height of each web to the nearest 0.1 in. [2.5 mm]. For each unit, calculate the minimum web area for each web ( $A_w$ ) by multiplying the minimum web thickness ( $t_w$ ) and minimum web height ( $t_h$ ) for measured web dimensions of 0.75 in. [19 mm] or greater. For each unit, calculate the total minimum web area ( $A_{wt}$ ) by summing the web area ( $A_w$ ) of each web.

A1.2.5.2 For units with webs that are not rectangular, disregard portions of the web that have a thickness of less than 0.75 in. [19 mm]. Make necessary measurements to determine the web area of each web at the minimum area based on the configuration of the web (see Note A1.2). For each unit,

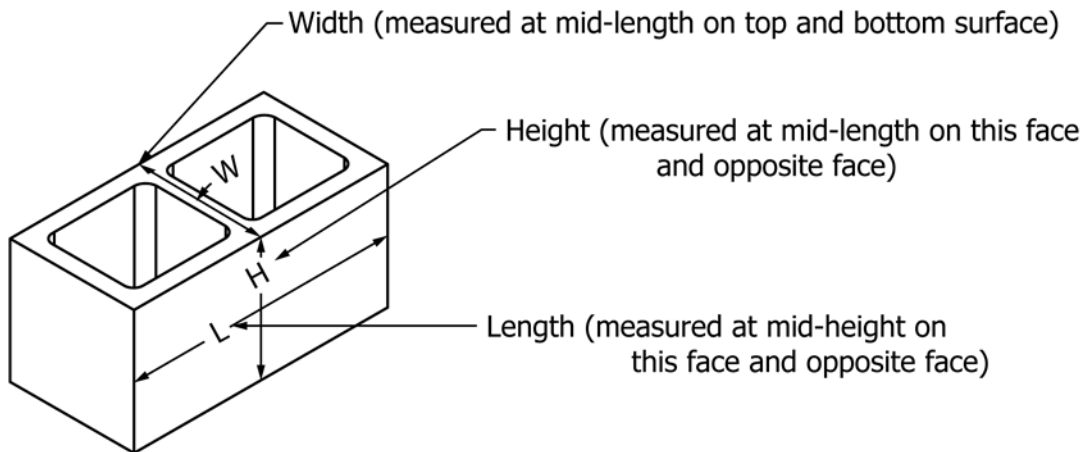

FIG. A1.1 Diagram Showing Location of Measurements for CMU

calculate the total minimum web area ( $A_{wr}$ ) by summing the web area ( $A_w$ ) of each web.

NOTE A1.1—Webs with minimum heights over their entire length or thickness over their entire height of less than 0.75 in. [19 mm] do not typically contribute to the unit's structural stability. Such webs should not be included in the minimum web area calculation. When a web has a portion that is less than 0.75 in. [19 mm] in thickness, the web area should be determined based only on the portions of the web that are larger than 0.75 in. [19 mm] in thickness. See Fig. A1.2 and Fig. A1.3.

NOTE A1.2—It can be difficult on some units to access the minimum web area. If necessary, the unit can be saw-cut along the length at the minimum web area to facilitate measurements. Fig. A1.3 shows an example of a non-rectangular web, where the upper portion would be discarded from the measurement because it is less than 0.75 in. [19 mm] in thickness, and the lower portion would be used to determine web area because it is greater than 0.75 in. [19 mm] in thickness.

### A1.3 Compressive Strength Testing

A1.3.1 *Test Specimens*—Specimens shall be full-sized units unless full-size units cannot be tested due to specimen configuration or testing machine requirements. When necessary, modify specimens as required in A1.3.1.1 through A1.3.1.3.

A1.3.1.1 *Unsupported projections* having a length greater than the thickness of the projection shall be removed by saw-cutting. For units with recessed webs, the face shell projecting above the web shall be removed by saw-cutting to provide a full bearing surface over the net cross section of the unit. Where the resulting unit height would be reduced by more than one-third of the original unit height, the unit shall be coupon tested in accordance with A1.3.1.3.

A1.3.1.2 When compression testing full-sized units that are too large for the test machine's bearing block and platens or are beyond the load capacity of the test machine, saw-cut the units to properly size them to conform to the capabilities of the testing machine. The resulting specimen shall have no face shell projections or irregular webs and shall be fully enclosed in a four-sided cell or cells. The compressive strength of the segment shall be considered to be the compressive strength of the whole unit.

A1.3.1.3 When compression testing units of unusual size and shape where a suitable reduced-size specimen in accordance with A1.3.1.2 cannot be obtained, (see Note A1.3 and Note A1.4), the specimens shall be saw-cut to remove any face

shell projections. The resulting specimen shall be a cell or cells containing four sides that will ensure a 100 % bearing surface. Where saw-cutting will not result in an enclosed four-sided unit, the specimen shall be a coupon cut from a face shell of each unit. The coupon shall be cut from the unit such that the coupon height dimension is in the same direction as the unit's height dimension. The compressive strength of the coupon shall be the net area compressive strength of the whole unit. The coupon size shall conform with the following:

(1) Targeted coupon width shall be equal to the face shell thickness and shall not be less than 0.75 in. [19 mm].

(2) Targeted aspect ratio (height divided by width,  $H_s/W_s$ ) of 2.0 before capping.

(3) Targeted length to width ratio ( $L_s/W_s$ ) of 4.0.

(4) Actual coupon dimensions shall not differ by more than 0.12 in. [3 mm] from targeted dimensions.

(5) Coupons shall be solid and not contain voids.

A1.3.1.4 If a coupon complying with A1.3.1.3 is used for compressive strength testing, measure the coupons in accordance with A1.3.2.

A1.3.2 *Coupon Measurement*—Coupon measurements shall be performed to the nearest 0.01 in. [0.25 mm] using a measurement device readable and accurate to 0.01 in. [0.25 mm]. Measurements shall be taken as follows:

A1.3.2.1 *Width*—Measure and record the width of the coupon ( $W_s$ ) across the top and bottom surfaces at mid-length. Average the two recorded values to determine the width of the coupon.

A1.3.2.2 *Height*—Measure and record the height of the coupon ( $H_s$ ) at mid-length on each face. Average the two recorded values to determine the height of the coupon.

A1.3.2.3 *Length*—Measure and record the length of the coupon ( $L_s$ ) at mid-height of each face. Average the two recorded values to determine the length of the coupon.

NOTE A1.3—Examples of units having unusual size or shape include, but are not limited to, bond beam units, open end units, and pilaster units.

NOTE A1.4—A full-size unit should be tested if feasible. If that is not feasible, then a reduced-size unit should be tested. If it is not feasible to test a full-size or reduced-size unit, then a coupon should be tested.

A1.3.3 *Testing*—Cap and test specimens in accordance with 7.3 and 7.4.

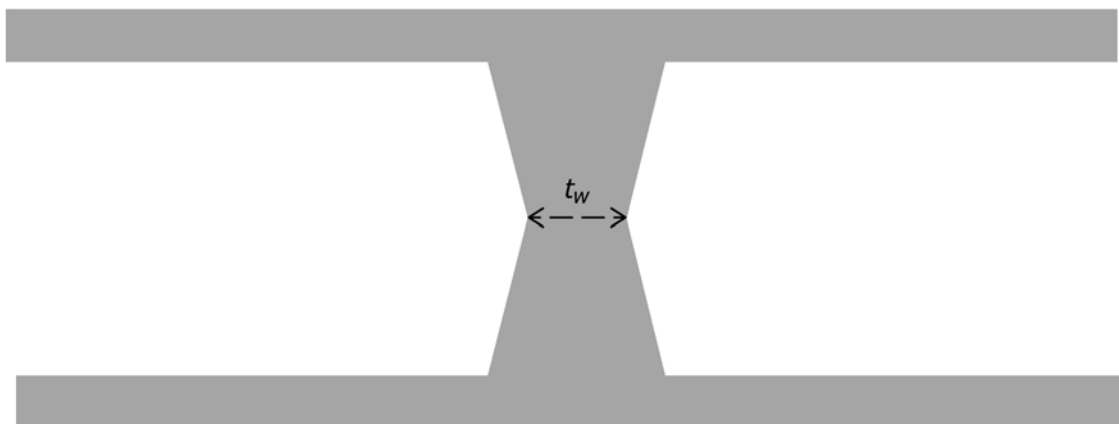

NOTE 1—If  $t_w$  is less than 0.75 in. [19 mm] over the entire height of the web, disregard entire area of that web when determining minimum web area.

**FIG. A1.2 Example of Web with Irregular Cross-section—Plan View**



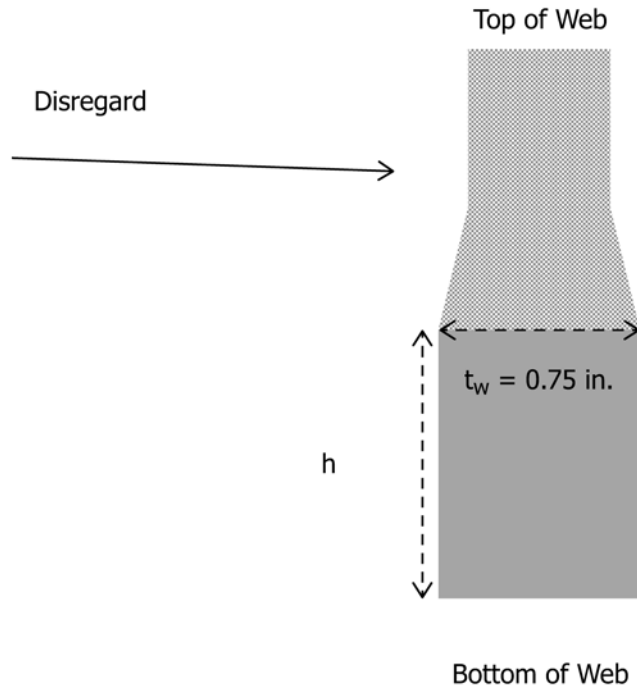

NOTE 1—Web Area =  $t_w * h$

FIG. A1.3 Example of Irregular Web Area Calculation—Section View

#### A1.4 Absorption Testing

A1.4.1 *Apparatus*—Absorption testing apparatus shall comply with 8.1.

A1.4.2 *Test Specimens*—Specimens shall be full-size or reduced-size specimens in accordance with 8.2 except as modified in A1.4.2.1.

A1.4.2.1 Tests shall be performed on full-size units when test results are to be used to determine moisture content in accordance with 9.2 or equivalent thickness in accordance with A1.5.3.

A1.4.3 *Testing*—Perform absorption tests in accordance with 8.3.

#### A1.5 Calculations

A1.5.1 Calculate absorption, moisture content, density, average net area, and net area compressive strength in accordance with Section 9.

A1.5.2 *Normalized Web Area*—Calculate the normalized web area ( $A_{wn}$ ) of each unit by dividing the total minimum web area ( $A_{wr}$ ) by the nominal length and height of the unit as follows:

$$A_{wn}(\text{in.}^2 / \text{ft}^2) = \frac{A_{wr}}{(L_n \times H_n)} \times 144 \quad (\text{A1.1})$$

$$\left[ A_{wn} (\text{mm}^2 / \text{m}^2) = \frac{A_{wr}}{(L_n \times H_n)} \times 10^6 \right]$$

where:

- $A_{wn}$  = normalized web area, in.<sup>2</sup>/ft<sup>2</sup> [mm<sup>2</sup>/m<sup>2</sup>],
- $A_{wr}$  = total minimum web area, in.<sup>2</sup> [mm<sup>2</sup>] (see A1.2.5),
- $L_n$  = nominal length of unit, in. [mm], and

$H_n$  = nominal height of unit, in. [mm].

NOTE A1.5—Minimum web area does not apply to the portion of the unit to be filled with grout. The portion of the unit to be filled with grout should be deducted from the calculation of the normalized web area.

A1.5.3 *Equivalent Thickness*—Equivalent thickness for concrete masonry is defined as the average thickness of solid material in the unit and is calculated as follows:

$$T_e, \text{ in.} = (V_n / (L \times H)) \times 1728 \quad (\text{A1.2})$$

$$[T_e, \text{ mm} = (V_n / (L \times H))]$$

where:

- $T_e$  = equivalent thickness, in. [mm],
- $V_n$  = average net volume of full-size units, ft<sup>3</sup> [mm<sup>3</sup>] (see 9.5),
- $L$  = average length of full-size units, in. [mm] (see A1.2.1), and
- $H$  = average height of full-size units, in. [mm] (see A1.2.1).

A1.5.3.1 Equivalent thickness shall only be calculated and reported for full-size concrete masonry units.

A1.5.4 *Percent Solid*—Calculate the percent solid as follows:

Inch-pound units:

$$\text{Percent solid, (\%)} = \left( \frac{(V_n \times 1728)}{(L \times W \times H)} \right) \times 100 \quad (\text{A1.3})$$

SI units:

$$\left[ \text{Percent solid, (\%)} = \left( \frac{V_n \times 1000}{(L \times W \times H)} \right) \times 100 \right] \quad (\text{A1.4})$$

where:

- $V_n$  = net volume of specimen, ft<sup>3</sup> [cm<sup>3</sup>] (see 9.5),



$L$  = average length of specimen, in. [mm] (see A1.2.1),  
 $W$  = average width of specimen, in. [mm] (see A1.2.1), and  
 $H$  = average height of specimen, in. [mm] (see A1.2.1).

NOTE A1.6—This calculation determines the percentage of concrete in the gross volume of the unit. It is a useful reference value, but it is not a requirement of unit specifications. This value is not comparable to the definition of a solid unit in C90 and C129, which refers to the net cross-sectional area of every plane parallel to the bearing surface relative to the gross cross-sectional area of the same plane.

#### A1.5.5 Maximum Variation from Specified Dimensions:

A1.5.5.1 Determine the variation from each specified dimension by calculating the average width, height, and length of each specimen and comparing each average to the respective specified dimension, resulting in three variation results for each unit and nine results for a set of units. Determine the maximum variation for the set by identifying the maximum of the nine values.

A1.5.5.2 Specified dimensions shall be obtained from the unit manufacturer.

### A1.6 Report

A1.6.1 Test reports shall include all of the information in Sections 10.2, 10.3, and the following:

A1.6.1.1 The minimum face shell thickness to the nearest 0.01 in. [0.25 mm] separately for each specimen and as the average for the three specimens tested.

A1.6.1.2 The minimum web thickness to the nearest 0.01 in. [0.25 mm] separately for each specimen and as the average for the three specimens tested.

A1.6.1.3 The normalized web area to the nearest 0.1 in.<sup>2</sup>/ft<sup>2</sup> [500 mm<sup>2</sup>/m<sup>2</sup>] as the average for the three specimens tested.

A1.6.1.4 The equivalent thickness to the nearest 0.1 in. [2.5 mm] as the average for the three specimens tested.

A1.6.1.5 The percent solid results to the nearest 0.1 % separately for each specimen and as the average for the three specimens tested.

A1.6.1.6 Maximum variation from specified dimensions to the nearest 0.1 in. [2.5 mm] for the set of specimens tested.

A1.6.1.7 The gross area to the nearest 0.1 in.<sup>2</sup> [50 mm<sup>2</sup>] separately for each specimen and as the average for the three specimens tested.

A1.6.1.8 The gross area compressive strength to the nearest 10 psi [0.1 MPa] separately for each specimen and as the average for the three specimens tested.

A1.6.1.9 The net volume to the nearest 0.01 ft<sup>3</sup> [250 cm<sup>3</sup>] separately for each specimen and as the average for the three specimens tested.

## A2. TEST PROCEDURES FOR CONCRETE AND CALCIUM SILICATE BRICK

### A2.1 Scope

A2.1.1 This annex includes testing requirements that are particular for concrete brick that are manufactured for compliance with the following unit specifications: C55, C73, and C1634.

### A2.2 Measurement of Dimension

A2.2.1 For each unit, measure and record the following to the nearest division required to be reported:

(1) Width ( $W$ ) at mid-length across the top and bottom bearing surfaces. Average the two recorded values to determine the width of the specimen.

(2) Height ( $H$ ) at mid-length on each face. Average the two recorded values to determine the height of the specimen.

(3) Length ( $L$ ) at mid-height on each face. Average the two recorded values to determine the length of the specimen.

A2.2.1.1 The width ( $W$ ) is the smaller average lateral dimension and the length ( $L$ ) is the larger average lateral dimension.

A2.2.2 For brick containing cores, measure 0.5 in. [13 mm] down from the top surface of the unit and record the minimum distance from the any edge of each brick to the nearest edge of the nearest core to the nearest division required to be reported.

### A2.3 Compressive Strength Testing

A2.3.1 *Test Specimens*—Specimens shall be full-sized units except as modified in A2.3.1.1 and A2.3.1.2.

A2.3.1.1 When compression testing full-sized units that are too large for the test machine's bearing block and platens or are beyond the load capacity of the test machine, saw-cut the units to properly size them to conform to the capabilities of the testing machine. The resulting specimen shall have no projections or irregular features and cores shall be fully enclosed. The compressive strength of the segment shall be considered to be the compressive strength of the whole unit.

A2.3.1.2 Test specimens shall have an aspect ratio (height divided by its width,  $H_s/W_s$ ) of  $0.6 \pm 0.1$ . The length of the test specimen shall not exceed 2.25 times the specimen width. If full-size units are not within that dimensional ratio requirement, the units shall be saw-cut to produce a compression test specimen with that dimensional ratio prior to capping. See Note A2.1. When a reduced size specimen is used for compressive strength testing, measure specimens in accordance with A2.3.2.

NOTE A2.1—It is preferable that the compression specimen have a height of at least 2 in. [50 mm]. For some concrete brick, it may not be possible to obtain this minimum height while maintaining the required aspect ratio. In these cases, the aspect ratio requirement should be met,

and the specimen should have a height as great as possible.

**A2.3.2 Reduced-size Specimen Measurement**—Reduced-size specimen measurements shall be performed to the nearest 0.01 in. [0.25 mm] using a measuring device readable and accurate to 0.01 in. [0.25 mm]. Measurements shall be taken as follows:

**A2.3.2.1 Width**—Measure and record the width of the reduced-size specimen ( $W_s$ ) across the top and bottom surfaces at mid-length. Average the two recorded values to determine the width of the reduced-size specimen.

**A2.3.2.2 Height**—Measure and record the height of the reduced-size specimen ( $H_s$ ) at mid-length on each face. Average the two recorded values to determine the height of the reduced-size specimen.

**A2.3.2.3 Length**—measure and record the length of the reduced-size specimen ( $L_s$ ) at mid-height of each face. Average the two recorded values to determine the length of the reduced-size specimen.

**A2.3.3 Testing**—Cap and test specimens in accordance with 7.3 and 7.4.

## A2.4 Absorption Testing

**A2.4.1 Apparatus**—Absorption testing apparatus shall comply with 8.1.

**A2.4.2 Test Specimens**—Specimens shall be full-size or reduced-size specimens in accordance with 8.2 except as modified in A2.4.2.1.

**A2.4.2.1** Tests shall be performed on full-size units when test results are to be used to determine equivalent thickness.

**A2.4.3 Testing**—Perform absorption tests in accordance with 8.3.

## A2.5 Calculations

**A2.5.1** Calculate absorption, moisture content, and density in accordance with Section 9.

**A2.5.2** For units tested to determine compliance with Specifications C55 or C1634, calculate net area in accordance with 9.5 and net area compressive strength in accordance with 9.7.1.

**A2.5.3** For units tested to determine compliance with Specification C73, calculate gross area in accordance with 9.6 and gross area compressive strength in accordance with 9.7.2.

**A2.5.4 Equivalent Thickness**—Equivalent thickness is defined as the average thickness of solid material in the unit and is calculated as follows:

$$T_e, \text{ in.} = (V_n / (L \times H)) \times 1728 \quad (\text{A2.1})$$

$$[T_e, \text{ mm} = (V_n / (L \times H))]$$

where:

$T_e$  = equivalent thickness, in. [mm],

$V_n$  = average net volume of full-size units, ft<sup>3</sup> [mm<sup>3</sup>] (see 9.5),

$L$  = average length of full-size units, in. [mm] (see A2.2.1), and

$H$  = average height of full-size units, in. [mm] (see A2.2.1).

**A2.5.4.1** Equivalent thickness shall only be calculated and reported for full-size concrete brick.

**A2.5.5 Percent Solid**—Calculate the percent solid as follows:

Inch-pound units:

$$\text{Percent solid, (\%)} = \left( \frac{V_n \times 1728}{L \times W \times H} \right) \times 100 \quad (\text{A2.2})$$

SI units:

$$\left[ \text{Percent solid, (\%)} = \left( \frac{V_n \times 1000}{L \times W \times H} \right) \times 100 \right] \quad (\text{A2.3})$$

where:

$V_n$  = net volume of specimen, ft<sup>3</sup> [cm<sup>3</sup>] (see 9.5),

$L$  = average length of specimen, in. [mm] (see A2.2.1),

$W$  = average width of specimen, in. [mm] (see A2.2.1), and

$H$  = average height of specimen, in. [mm] (see A2.2.1).

**NOTE A2.2**—This calculation determines the percentage of concrete in the gross volume of the unit. It is a useful reference value, but it is not a requirement of unit specifications. This value is not comparable to the definition of a solid unit in C55 and C1634, which refers to the net cross-sectional area of every plane parallel to the bearing surface relative to the gross cross-sectional area of the same plane.

## A2.6 Report

**A2.6.1** Test reports shall include all of the information in Sections 10.2, 10.3, and the following:

**A2.6.1.1** For cored units, the minimum distance from the edge of the brick to the nearest core to the nearest 0.1 in. [2.5 mm] separately for each specimen and as the average for the three specimens tested.

**A2.6.1.2** The equivalent thickness to the nearest 0.1 in. [2.5 mm] as the average for the three specimens tested.

**A2.6.1.3** The percent solid results to the nearest 0.1 % separately for each specimen and as the average for the three specimens tested.

**A2.6.1.4** The gross area to the nearest 0.1 in<sup>2</sup> [50 mm<sup>2</sup>] separately for each specimen and as the average for the three specimens tested.

**A2.6.1.5** The gross area compressive strength to the nearest 10 psi [0.1 MPa] separately for each specimen and as the average for the three specimens tested.

**A2.6.1.6** The net volume to the nearest 0.01 ft<sup>3</sup> [250 cm<sup>3</sup>] separately for each specimen and as the average for the three specimens tested.

A3. TEST PROCEDURES FOR SEGMENTAL RETAINING WALL UNITS

A3.1 Scope

A3.1.1 This annex includes testing requirements that are particular for segmental retaining wall units that are manufactured for compliance with the following unit specifications: C1372.

A3.2 Sampling

A3.2.1 A set shall consist of a minimum of three full-size units, unless freeze-thaw durability testing is required. When freeze-thaw durability testing is required, a set shall consist of a minimum of five full-size units.

A3.3 Measurement of Dimensions

A3.3.1 For each unit, measure and record the following to the nearest division required to be reported:

- (1) Width ( $W$ ) at mid-length across the top and bottom bearing surfaces. Average the two recorded values to determine the width of the specimen.
- (2) Length ( $L$ ) at mid-height at the front and back of the specimen. Average the two recorded values to determine the length of the specimen.

A3.3.2 For each unit, measure and record the height ( $H$ ) at the four bearing corners and mid-length at the front and back of the specimen to the nearest division required to be reported (see Fig. A3.1). If lips or similar projections are present, the projection shall be ignored and the height measurements taken from the bearing surface behind or in front of the projection on the main bearing surface of the unit (see Fig. A3.2). Average the six recorded values to determine the height of the specimen.

NOTE A3.1—When a projection is present, the height can be determined from the height at the inside of the core (if present) or by taking the total unit height (including the projection) and subtracting the height of the projection.

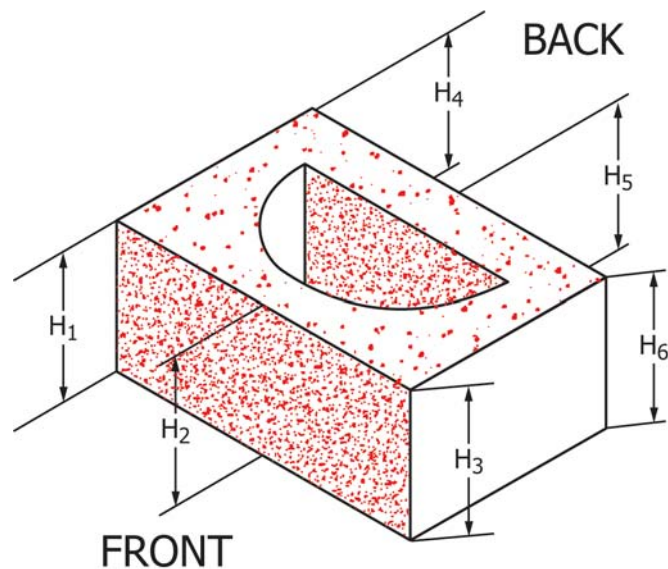

FIG. A3.1 Height Measurements for SRW Units

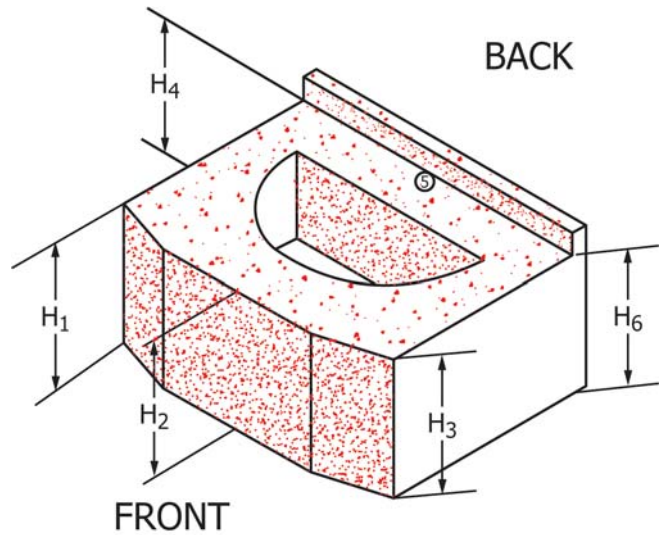

FIG. A3.2 Height Measurements for SRW Units with Raised Lip

A3.4 Compressive Strength Testing

A3.4.1 Test Specimens—Specimens shall be a saw-cut coupon. The compressive strength of the coupon shall be considered to be the compressive strength of the whole unit. Saw-cutting shall be performed in accordance with 7.2.4 and 7.2.5. The coupon size shall conform with the following:

- (1) Targeted coupon width shall be as close to 2 in. [50 mm] as possible, but in no case less than 1.5 in. [40 mm].
- (2) Targeted aspect ratio (height divided by width,  $H_s/W_s$ ) of 2.0 before capping.
- (3) Targeted length to width ratio ( $L_s/W_s$ ) of 4.0.
- (4) Actual coupon dimensions shall not differ by more than 0.12 in. [3 mm] from targeted dimensions.
- (5) Coupons shall be solid and not contain voids.

A3.4.1.1 Measure coupons in accordance with A3.4.2.

A3.4.2 Coupon Measurement—Coupon measurements shall be performed to the nearest 0.01 in. [0.25 mm] using a measurement device readable and accurate to 0.01 in. [0.25 mm]. Measurements shall be taken as follows:

A3.4.2.1 Width—measure and record the width of the coupon ( $W_s$ ) across the top and bottom surfaces at mid-length. Average the two recorded values to determine the width of the coupon.

A3.4.2.2 Height—Measure and record the height of the coupon ( $H_s$ ) at mid-length on each face. Average the two recorded values to determine the height of the coupon.

A3.4.2.3 Length—Measure and record the length of the coupon ( $L_s$ ) at mid-height of each face. Average the two recorded values to determine the length of the coupon.

NOTE A3.2—The compressive strength of coupons saw-cut from segmental retaining wall units can be measurably influenced by the unit configuration and location of the sample. Due to the variety of unit configurations available, it is not possible to specify exact locations for obtaining coupons. In order to compare results within a set or between independently performed tests, coupons should be consistently obtained from the same location for a given unit configuration. Suppliers should be

consulted for the recommended coupon sample location for a given unit configuration.

A3.4.3 *Testing*—Cap and test specimens in accordance with 7.3 and 7.4.

### A3.5 Absorption Testing

A3.5.1 *Apparatus*—Absorption testing apparatus shall comply with 8.1.

A3.5.2 *Test Specimens*—Specimens shall be full-size or reduced-size specimens in accordance with 8.2.

A3.5.3 *Testing*—Perform absorption tests in accordance with 8.3.

### A3.6 Calculations

A3.6.1 Calculate absorption, density, net area, and net area compressive strength in accordance with Section 9.

### A3.7 Report

A3.7.1 Test reports shall include all of the information in 10.2 and the following:

A3.7.1.1 The average width and height to the nearest 0.1 in. [2.5 mm] separately for each specimen and as the average for the three specimens tested.

A3.7.1.2 The front length to the nearest 0.1 in. [2.5 mm] separately for each specimen and as the average for the three specimens tested.

A3.7.1.3 The rear length to the nearest 0.1 in. [2.5 mm] separately for each specimen and as the average for the three specimens tested.

A3.7.1.4 The net area to the nearest 0.1 in.<sup>2</sup> [50 mm<sup>2</sup>] separately for each specimen and as the average for the three specimens tested.

A3.7.1.5 The maximum load separately for each specimen and as the average for the three specimens tested. Record the load as indicated to the nearest 10 lb [50 N] or the minimum resolution of the test machine as used during testing, whichever is greater.

A3.7.1.6 The net area compressive strength to the nearest 10 psi [0.1 MPa] separately for each specimen and as the average for the three specimens tested.

A3.7.1.7 The immersed, saturated, and oven dry weights ( $w_i$ ,  $w_s$ , and  $w_d$ ) to the nearest 0.1 lb [0.05 kg] separately for each specimen and as the average for the three specimens tested.

A3.7.1.8 The absorption to the nearest 0.1 lb/ft<sup>3</sup> [1 kg/m<sup>3</sup>] separately for each specimen and as the average for the three specimens tested.

A3.7.1.9 The density to the nearest 0.1 lb/ft<sup>3</sup> [1 kg/m<sup>3</sup>] separately for each specimen and as the average for the three specimens tested.

A3.7.1.10 The size and configuration of the specimens tested for compressive strength and absorption.

## A4. TEST PROCEDURES FOR CONCRETE INTERLOCKING PAVING UNITS

### A4.1 Scope

A4.1.1 This annex includes testing requirements that are particular for concrete interlocking paving units that are manufactured for compliance with the following unit specifications: C936/C936M.

### A4.2 Measurement of Dimensions

A4.2.1 For each full-sized unit sampled for compressive strength testing, measure and record the following using a caliper readable and accurate to 0.002 in. [0.1 mm]:

(1) Width ( $W$ ) at mid-length across the top and bottom bearing surfaces. Average the two recorded values to determine the width of the specimen.

(2) Thickness ( $T$ ) at mid-length on each side. Average the two recorded values to determine the thickness of the of the specimen.

(3) Length ( $L$ ) at mid-width across the top and bottom bearing surfaces. Average the two recorded values to determine the length of the specimen.

A4.2.1.1 Disregard spacer tabs when performing length and width measurements.

A4.2.1.2 The width ( $W$ ) is the smaller average lateral dimension and the length ( $L$ ) is the larger average lateral dimension.

A4.2.2 For pavers with chamfers, disregard the chamfer and measure thickness from the bottom surface to the top surface of the specimen along the portion of the top surface without the chamfer. See Fig. A4.1.

### A4.3 Compressive Strength Testing

A4.3.1 *Test Specimens*—Test full size units that comply with all the requirements of A4.3.1.2. If full size units do not comply with all of the requirements of A4.3.1.2, then cut a rectangular full-height specimen from the units by reducing the width or length or both to meet all of the requirements of A4.3.1.2. If the smoothness or the aspect ratio required in A4.3.1.2 cannot be achieved with a full-height specimen, cut the specimen height to achieve the required smoothness and aspect ratio. If saw-cutting is required to achieve specimen size or configuration requirements in A4.3.1.2, follow the procedures in 7.2.4.

A4.3.1.1 For any cuts that reduce the thickness of the pavers, cut off the top of the paver and discard. Verify the accuracy of cut by measuring and recording as  $T_c$  the thickness of the cut specimen at mid-length of each side. Discard any specimen if the difference in  $T_c$  at the two different points is greater than 0.08 in. [2.0 mm].





FIG. A4.1 Measuring Thickness of Paver with Chamfer (Section view from end of paver)

A4.3.1.2 Compression specimens shall (1) have a cross-section about any principal axis that is a rectangle; (2) have a face area with a length no greater than 2.1 times the width; (3) have no grooves, chamfers, or dummy joints on the top face, except those intentionally manufactured on the edges of the specimen; (4) have no texture on the top surface where the difference in height between the highest and lowest point across the surface face is greater than 0.06 in. [1.5 mm] except for chamfers intentionally manufactured on the edges of the specimen; and (5) have an aspect ratio (thickness divided by width of the compression specimen,  $T_s / W_s$ ) of 0.58 to 1.20.

A4.3.1.3 If saw-cutting is required to achieve specimen size and configuration requirements, measure and record the following to the nearest 0.002 in. [0.1 mm] for each specimen:

- (1) Width ( $W_s$ ) across the top and bottom surfaces at mid-length.
- (2) Thickness ( $T_s$ ) at mid-length of each side.
- (3) Length ( $L_s$ ) across the top and bottom surfaces at mid-width.

When full-size specimens are tested in compression, consider  $T_s$ ,  $W_s$ , and  $L_s$  to be  $T$ ,  $W$ , and  $L$ , respectively, as measured in A4.2.1.

A4.3.2 Capping—Cap test specimens in accordance with Practice C1552 except as modified below.

A4.3.2.1 Use high strength gypsum cement capping material only.

A4.3.2.2 The average cap thickness for each unit shall not exceed 0.06 in. [1.5 mm].

A4.3.2.3 Determine the average thickness of the cap as follows: after capping both sides of the specimen, measure and record the thickness of the capped specimen to the nearest 0.002 in. [0.1 mm] at the same two points where thickness of the uncapped specimen was measured in accordance with either (1) A4.2.1 if the pavers were not cut to reduce thickness or (2) A4.3.1.1 if the pavers were cut to reduce thickness. Calculate the difference in thickness for each point and divide by 2 to determine the calculated cap thickness at each point. Calculate the average cap thickness for the whole specimen by taking the average of the calculated cap thickness at each of the two points.

NOTE A4.1—An important factor in producing high-quality gypsum caps is to use a water-to-cement ratio that yields a capping material that is fluid enough to spread while being viscous enough to allow the paver to be pushed into it forming a consistent thin cap.

A4.3.3 Testing—Test specimens in accordance with 7.4.

#### A4.4 Absorption Testing

A4.4.1 Apparatus—Absorption testing apparatus shall comply with 8.1 except as modified in A4.4.1.1 and A4.4.1.2.

A4.4.1.1 The balance used shall be readable and accurate to 0.05 % of the smallest specimen tested.

A4.4.1.2 Record the immersed, saturated, and oven dry weights ( $w_i$ ,  $w_s$ , and  $w_d$ ) to the accuracy required in Table A4.1.

A4.4.2 Test Specimens—Specimens shall be full-size or reduced-size specimens in accordance with 8.2.

A4.4.3 Testing—Perform absorption tests in accordance with 8.3.

#### A4.5 Calculations

A4.5.1 Calculate the absorption and density in accordance with Section 9.

A4.5.2 Calculate net area compressive strength of the specimen as follows:

$$\text{Net Area } (A_n) \text{ in.}^2 [\text{mm}^2] = L_s \times W_s \quad (\text{A4.1})$$

$$\text{Aspect Ratio } (R_a) = T_s / W_s \quad (\text{A4.2})$$

$$\text{Aspect Ratio Factor } (F_a) = (-0.374 / R_a) + 1.611 \quad (\text{A4.3})$$

$$\text{Net Area Compressive Strength, psi [MPa]} = (P_{max} / A_n) \times F_a \quad (\text{A4.4})$$

where:

- $A_n$  = average net area of specimen, in.<sup>2</sup> [mm<sup>2</sup>],
- $L_s$  = average length of the final test specimen, in. [mm],
- $W_s$  = average width of the final test specimen, in. [mm],
- $R_a$  = aspect ratio,
- $T_s$  = average uncapped thickness of the final test specimen, in. [mm],
- $F_a$  = aspect ratio factor (see Note A4.2), and
- $P_{max}$  = maximum compressive load, lb [N].

NOTE A4.2—The aspect ratio factors are normalized so that a common

TABLE A4.1 Required Accuracy for Recording and Reporting Specimen Weights

Absorption Specimen	Required Accuracy
Less than 10 lb [4 kg]	0.002 lb [0.001 kg]
10 to 20 lb [4 to 10 kg]	0.005 lb [0.002 kg]
Greater than 20 lb [10 kg]	0.01 lb [0.005 kg]

2.36-in. [60-mm] thick rectangular 3.86 × 7.80 in. [98 × 198 mm] paver with an aspect ratio of 0.612 has an aspect ratio factor of 1.00. Based on Eq A4.3, the aspect ratio factors for rectangular 3.86 × 7.80 in. [98 × 198 mm] pavers of various thicknesses are shown in the following table:

Thickness, in. [mm]	Aspect Ratio ( $R_a$ )	Aspect Ratio Factor ( $F_a$ )
2.36 [60]	0.612	1.00
2.76 [70]	0.714	1.09
3.15 [80]	0.816	1.15
3.54 [90]	0.918	1.20
3.94 [100]	1.020	1.24
4.33 [110]	1.122	1.28
4.72 [120]	1.224	1.31

**A4.6 Report**

A4.6.1 Test reports shall include all of the information in Section 10.2 and the following:

A4.6.1.1 The average width,  $W$ , thickness,  $T$ , and length,  $L$ , to the nearest 0.002 in. [0.1 mm] separately for each full-sized, sampled unit and as the average for the three units tested.

A4.6.1.2 The dimensions of the compression specimens ( $W_s$ ,  $T_s$ , and  $L_s$ ), to the nearest 0.002 in. [0.1 mm], if different from the full-size units, including the difference in  $T_c$  value across the face of the paver if the specimen was cut to reduce thickness.

A4.6.1.3 The net area to the nearest 0.1 in.<sup>2</sup> [50 mm<sup>2</sup>] separately for each compression specimen and as the average for the three specimens tested.

A4.6.1.4 The average cap thickness to the nearest 0.002 in. [0.1 mm] for each compression specimen and as the average for the set of three specimens tested.

A4.6.1.5 The maximum load separately for each specimen and as the average for the three specimens tested. Record the load as indicated to the nearest 10 lb [50 N] or the minimum resolution of the test machine as used during testing, whichever is greater.

A4.6.1.6 The aspect ratio,  $R_a$ , and aspect ratio factor,  $F_a$ , for each compressive strength test specimen.

A4.6.1.7 The net area compressive strength to the nearest 10 psi [0.1 MPa] separately for each specimen and as the average for three specimens tested.

A4.6.1.8 The immersed, saturated, and oven dry weights ( $w_i$ ,  $w_s$ , and  $w_d$ ) to the accuracy required in Table A4.1 separately for each specimen and as an average for the three specimens tested.

A4.6.1.9 The absorption results to the nearest 0.1 % and density results to the nearest 0.1 lb/ft<sup>3</sup> [1 kg/m<sup>3</sup>] separately for each unit and as the average for the three specimens tested. If absorption tests are performed on specimens other than full-size units, report the reason for testing reduced-size units.

A4.6.1.10 Two sample test reports showing examples of reports that meet all of the requirements of this section are shown in the nonmandatory Appendix X2.

**A5. TEST PROCEDURES FOR CONCRETE GRID PAVING UNITS**

**A5.1 Scope**

A5.1.1 This annex includes testing requirements that are particular for concrete grid paving units that are manufactured for compliance with the following unit specifications: C1319.

**A5.2 Sampling**

A5.2.1 *Sampling*—A minimum of six specimens shall be selected for each test set.

**A5.3 Measurement of Dimensions**

A5.3.1 For each unit, measure and record the following to the nearest division required to be reported (see Fig. A5.1).

(1) Width ( $W$ ) across the top and bottom bearing surfaces at the maximum width of the unit. Average the two recorded values to determine the width of the specimen.

(2) Thickness ( $T$ ) at mid-length of each face. Average the two recorded values to determine the thickness of the specimen.

(3) Length ( $L$ ) across the top and bottom bearing surfaces at the maximum length of the unit. Average the two recorded values to determine the length of the specimen.

NOTE A5.1—Fig. A5.1 shows a representative example of how to properly measure and obtain specimens from a common unit shape. There are many other shapes and sizes of grid paving units available which may require different procedures for measuring and obtaining specimens. Suppliers should be consulted for recommended specimen sampling procedures.

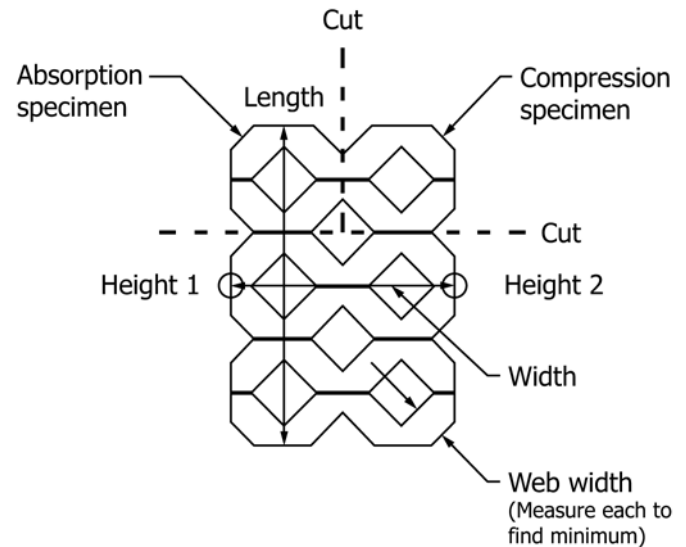

**FIG. A5.1 Typical Grid Paver Configuration**

A5.3.2 For each unit, measure the width of each web at the thinnest point. Record the minimum value measured. For the web with the minimum thickness, measure and record two additional web readings. The two additional readings shall be at the maximum width of the web and at mid-thickness of the web. Measure and record all web width measurements to the

nearest division required to be reported. Disregard grooves, scores, and similar details in the measurements.

#### A5.4 Compressive Strength Testing

A5.4.1 *Test Specimens*—Three units shall be tested for compressive strength. Specimens shall be full-sized units or reduced-size units as modified in A5.4.1.1 or A5.4.1.2.

A5.4.1.1 When compression testing full-sized units that are too large for the test machine's bearing block and platens or are beyond the load capacity of the test machine, saw-cut the units to properly size them to conform to the capabilities of the testing machine. The resulting specimen shall be symmetrical, have no projections or irregular features, and shall be a fully enclosed cell or cells with a full bearing surface. The compressive strength of the segment shall be considered to be the compressive strength of the whole unit.

A5.4.1.2 If it is not possible to obtain a specimen that is symmetrical with no projections or irregular features and a fully enclosed cell or cells, the specimen shall be a coupon cut from the unit. The compressive strength of the coupon shall be considered to be the compressive strength of the whole unit. Saw-cutting shall be performed in accordance with 7.2.4 and 7.2.5. The coupon shall conform with the following:

- (1) Targeted coupon height shall not be less than the minimum height of the webs.
- (2) Targeted aspect ratio (height divided by width,  $H_s/W_s$ ) of 2.0 before capping.
- (3) Targeted length to width ratio ( $L_s/W_s$ ) of 4.0.
- (4) Actual coupon dimensions shall not differ by more than 0.12 in. [3 mm] from targeted dimensions.
- (5) Coupons shall be solid and not contain voids.

NOTE A5.2—An example of a unit that will require coupon testing would be one that has depressions in some of the webs that prevents obtaining a fully enclosed cell with a full bearing surface.

A5.4.1.3 If a coupon complying with to A1.3.1.3 is used for compressive strength testing, measure the coupons in accordance with A1.3.2.

A5.4.2 *Coupon Measurement*—Coupon measurements shall be performed to the nearest 0.01 in. [0.25 mm] using a measurement device readable and accurate to 0.01 in. [0.25 mm]. Measurements shall be taken as follows:

A5.4.2.1 *Width*—Measure and record the width of the coupon ( $W_s$ ) across the top and bottom surfaces at mid-length. Average the two recorded values to determine the width of the coupon.

A5.4.2.2 *Height*—Measure and record the height of the coupon ( $H_s$ ) at mid-length on each face. Average the two recorded values to determine the height of the coupon.

A5.4.2.3 *Length*—Measure and record the length of the coupon ( $L_s$ ) at mid-height of each face. Average the two recorded values to determine the length of the coupon.

A5.4.3 *Testing*—Cap and test specimens in accordance with 7.3 and 7.4.

#### A5.5 Absorption Testing

A5.5.1 *Apparatus*—Absorption testing apparatus shall comply with 8.1.

A5.5.2 *Test Specimens*—Specimens shall be full-size or reduced-size specimens in accordance with 8.2 except as modified by A5.5.2.1.

A5.5.2.1 When compression specimens are other than full-size units, absorption testing shall be performed on specimens saw-cut from full-size units with the same configuration as the reduced-size units used for compression testing.

A5.5.3 *Testing*—Perform absorption tests in accordance with 8.3.

#### A5.6 Full Size Net Area Testing

A5.6.1 Three full size units shall be tested for net area.

A5.6.2 Determine the net cross-sectional area of full-size units by performing absorption testing on full-size units in accordance with 8.3.

#### A5.7 Calculations

A5.7.1 Calculate absorption, density, net area, and net area compressive strength in accordance with Section 9. For determination of net area, absorption, and density, use data collected from testing in accordance with A5.5.1.

A5.7.2 Calculate the full-size net area ( $A_{n,full}$ ) in accordance with Section 9 using the data collected from the testing in accordance with A5.6.

A5.7.3 Calculate the percent solid as follows:

$$\text{Percent solid} = ((A_{n,full})/L \times W) \times 100 \quad (\text{A5.1})$$

where:

$A_{n,full}$  = full-size net area, in.<sup>2</sup> [mm<sup>2</sup>] (A5.7.2)  
 $L$  = full-size unit length, in. [mm], and  
 $W$  = full-size unit width, in. [mm].

#### A5.8 Report

A5.8.1 Test reports shall include all of the information in Sections 10.2, 10.3, and the following:

A5.8.1.1 The minimum web width and average web width to the nearest 0.01 in. [0.25 mm] of each specimen as determined by A5.3.1 The average web width is calculated from the three readings of the web with the minimum width.

A5.8.1.2 The full-size net area to the nearest 0.1 in.<sup>2</sup> [50 mm<sup>2</sup>] as the average of the set of three specimens as determined by A5.7.2.

A5.8.1.3 The average percent solid for the set of three units to the nearest 0.1 % as determined by A5.7.3.

## A6. TEST PROCEDURES FOR CONCRETE ROOF PAVERS

### A6.1 Scope

A6.1.1 This annex includes testing requirements that are particular for concrete roof pavers that are manufactured for compliance with the following unit specifications: **C1491**.

### A6.2 Sampling

A6.2.1 A set shall consist of a minimum of nine full-size units.

### A6.3 Measurement of Dimensions

A6.3.1 For each unit, measure and record the following to the nearest division required to be reported:

(1) Width ( $W$ ) at mid-length across the top and bottom bearing surfaces. Average the two recorded values to determine the width of the specimen.

(2) Thickness ( $T$ ) at mid-length on each face. Average the two recorded values to determine the thickness of the specimen.

(3) Length ( $L$ ) at mid-thickness on each face. Average the two recorded values to determine the length of the specimen.

### A6.4 Compressive Strength Testing

A6.4.1 For concrete roof paver compressive strength tests, cut three test specimens from three whole paver units. Each specimen shall consist of a strip of paver with specimen thickness equal to specimen width. The length of the specimen shall be equal to the length of the unit or 8 in. [200 mm], whichever is less. Where a unit contains supporting ribs, obtain specimens by cutting perpendicular to the direction of the ribs so as to avoid inclusion of beveled or recessed surfaces at top or bottom edges (see **Fig. A6.1**).

A6.4.2 *Testing*—Cap and test specimens in accordance with **7.3** and **7.4**.

### A6.5 Absorption Testing

A6.5.1 *Apparatus*—Absorption testing apparatus shall comply with **8.1**.

A6.5.2 *Test Specimens*—Specimens shall be full-size or reduced-size specimens in accordance with **8.2**.

A6.5.3 *Testing*—Perform absorption tests in accordance with **8.3**.

### A6.6 Flexural Load Testing

A6.6.1 Three full-sized units shall be tested.

A6.6.2 *Capping*—Units with wearing (top) surfaces containing recesses or other irregularities shall have such recesses capped flush with the uppermost surface in accordance with Practice **C1552**.

A6.6.3 *Testing*—The testing arrangement shall be as shown in **Fig. A6.2**. The load from the upper bearing block of the testing machine shall be applied through the centroid of the concrete roof paver by the bearing assembly illustrated. The flexural length of the paver unit is taken as the end-to-end plan dimension of the units. Loading shall be applied at a uniform rate such that the total load is applied in not less than 1 min and not less than 3 min.

### A6.7 Calculations

A6.7.1 Calculate absorption, density, net area, and net area compressive strength in accordance with Section **9**.

A6.7.2 *Ballast Weight*—For concrete roof pavers, calculate ballast weight as follows:

$$w_b, \text{lb/ft}^2 = (w_d)/(A_g) \times 144 \quad (\text{A6.1})$$

$$[w_b, \text{kg/m}^2 = (w_d)/(A_g) \times 10^6]$$

where:

$w_b$  = ballast weight, lb/ft<sup>2</sup> [kg/m<sup>2</sup>],

$w_d$  = oven-dry weight of unit, lb [kg] (see **8.3.4**), and

$A_g$  = gross area of unit, in.<sup>2</sup> [mm<sup>2</sup>] (see **9.6**).

### A6.8 Report

A6.8.1 Test reports shall include all of the information in Sections **10.2**, **10.3**, and the following:

A6.8.2 The flexural load to the nearest 1 lb [5 N] required to fail a specimen separately and as the average for the set of three units tested.

A6.8.3 Ballast weight to the nearest 1 psf [5 kg/m<sup>2</sup>] separately for each specimen and as the average for the set of three specimens tested.



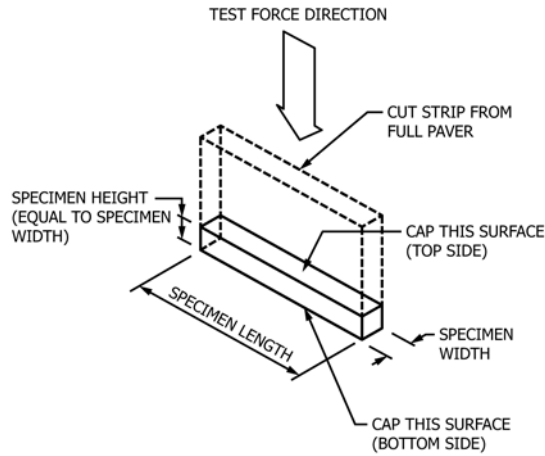

FIG. A6.1 Compressive Strength Test Setup for Concrete Roof Pavers

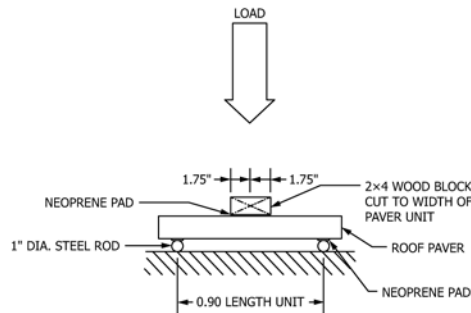

FIG. A6.2 Flexural Strength Test Setup for Concrete Roof Pavers

## A7. TEST PROCEDURES FOR DRY CAST ARTICULATING CONCRETE BLOCK

### A7.1 Scope

A7.1.1 This annex includes testing requirements for dry cast articulating concrete block that are manufactured for compliance with the following unit specification: [D6684](#).

### A7.2 Sampling

A7.2.1 A set shall consist of a minimum of three full-size units, unless freeze-thaw durability testing is required. When freeze-thaw durability testing is required, a set shall consist of a minimum of five full-size units.

### A7.3 Measurement of Dimensions

A7.3.1 For each unit, measure and record the following to the nearest division required to be reported:

(1) Width ( $W$ ) at mid-length across the top and bottom bearing surfaces. Average the two recorded values to determine the width of the specimen.

(2) Height ( $H$ ) at mid-length on each face. Average the two recorded values to determine the thickness of the specimen.

(3) Length ( $L$ ) at mid-height on each face. Average the two recorded values to determine the length of the specimen.

### A7.4 Compressive Strength Testing

A7.4.1 *Test Specimens*—Specimens shall be a saw-cut coupon. The compressive strength of the coupon shall be considered to be the compressive strength of the whole unit. Saw-cutting shall be performed in accordance with [7.2.4](#) and [7.2.5](#). The coupon size shall comply with the following:

(1) Targeted coupon width shall be as close to 2 in. [50 mm] as possible, but in no case less than 1.5 in. [40 mm].

(2) Targeted aspect ratio (height divided by width,  $H_s/W_s$ ) of 2.0 before capping.

(3) Targeted length to width ratio ( $L_s/W_s$ ) of 4.0.

(4) Actual coupon dimensions shall not differ by more than 0.12 in. [3 mm] from targeted dimensions.

(5) Coupons shall be solid and not contain cable holes or other voids.

A7.4.1.1 Measure coupons in accordance with [A3.4.2](#).

**A7.4.2 Coupon Measurement**—Coupon measurements shall be performed to the nearest 0.01 in. [0.25 mm] using a measurement device readable and accurate to 0.01 in. [0.25 mm]. Measurements shall be taken as follows:

**A7.4.2.1 Width**—Measure and record the width of the coupon ( $W_s$ ) across the top and bottom surfaces at mid-length. Average the two recorded values to determine the width of the coupon.

**A7.4.2.2 Height**—Measure and record the height of the coupon ( $H_s$ ) at mid-length on each face. Average the two recorded values to determine the height of the coupon.

**A7.4.2.3 Length**—Measure and record the length of the coupon ( $L_s$ ) at mid-height of each face. Average the two recorded values to determine the length of the coupon.

**NOTE A7.1**—The compressive strength of coupons saw-cut from articulating concrete blocks can be measurably influenced by the unit configuration and location of the sample. Due to the variety of unit configurations available, it is not possible to specify exact locations for obtaining coupons. In order to compare results within a set or between independently performed tests, coupons should be consistently obtained from the same location for a given unit configuration. Suppliers should be

consulted for the recommended coupon sample location for a given unit configuration.

**A7.4.3 Testing**—Cap and test specimens in accordance with **7.3** and **7.4**.

## **A7.5 Absorption Testing**

**A7.5.1 Apparatus**—Absorption testing apparatus shall comply with **8.1**.

**A7.5.2 Test Specimens**—Specimens shall be full-size or reduced-size specimens in accordance with **8.2**.

**A7.5.3 Testing**—Perform absorption tests in accordance with **8.3**.

## **A7.6 Calculations**

**A7.6.1** Calculate absorption, density, net area, and net area compressive strength in accordance with Section **9**.

## **A7.7 Report**

**A7.7.1** Test reports shall include all of the information in Sections **10** and **10.3**.

# **APPENDIXES**

## **(Nonmandatory Information)**

### **X1. WORKSHEET AND TEST REPORT FOR CONCRETE MASONRY UNITS**

**X1.1** Included in this section is a sample laboratory worksheet and a test report form. These samples were developed for use in recording and reporting test information for conventional concrete masonry units to determine their compliance with Specification **C90**. These forms are to be used as

guidelines only. Users of these test methods may use or modify these forms to suit their purposes and to address the requirements of the test methods as they apply to the specific specimens being tested.

**ASTM C140-12 Worksheet**  
**Sampling and Testing Concrete Masonry Units**

 Project Number 12-100  
 Date Received 9/8/2012  
 Report Date 9/20/2012

Client:	Big Block Plant	Testing Agency:	Accurate Testing Laboratory
Address:	111 Block Drive Anytown, USA 12345	Address:	123 Main Street Anytown, USA 12345
Contact Name:		Sampling Party:	Big Block Plant
Project ID:	Standard I		
Unit Description:	8 × 8 × 16 Inch Concrete Masonry Unit	Overall Nominal Dimensions:	Width (in.) 8.00 Height (in.) 8.00 Length (in.) 16.00

**Compression Units**

(Determine the following information for each of the three units to be tested in compression.)

	#1	#2	#3			
Received Weight (WR)	32.48	31.22	30.92	lb.	Date:	9/10/2012
Max. Compressive Load (P <sub>MA</sub> )	129770	113950	114690	lb.	Date:	9/17/2012

**Absorption Units**

(Determine the following information for each of the three units to be immersed in water for absorption testing.)

	#4	#5	#6			
Width (W) @ Top	7.62	7.64	7.64	in.		
@ Bottom	7.63	7.65	7.63	in.		
Height (H) @ Face 1	7.54	7.61	7.66	in.		
@ Face 2	7.52	7.61	7.67	in.		
Length (L) @ Face 1	15.62	15.61	15.62	in.	Measurements...	
@ Face 2	15.60	15.62	15.63	in.	Date:	9/10/2012
Faceshell Thickness (FST)						
@ Face 1	1.28	1.38	1.37	in.		
@ Face 2	1.24	1.37	1.37	in.		
Web Measurements						
	Unit 4		Unit 5		Unit 6	
	Thickness	Height	Thickness	Height	Thickness	height
@ Web 1	1.06	7.53	1.12	7.61	1.18	7.67
@ Web 2	1.04	7.53	1.14	7.61	1.14	7.67
@ Web 3	0.99	7.53	1.18	7.61	1.18	7.67
@ Web 4						
Received Weight (W <sub>R</sub> )	32.07	31.24	30.90	lb.	Date:	9/10/2012
Immersed Weight (W <sub>I</sub> )	16.85	16.22	16.05	lb.		
Saturated Weight (W <sub>S</sub> )	33.27	32.76	32.51	lb.	Date:	9/17/2012
Final Oven-Dry Weight (W <sub>D</sub> )	30.18	29.33	29.14	lb.	Date:	9/19/2012

Intermediate Drying Weights (first reading after at least 24 hours drying, successive readings at 2 hr intervals)

1st	30.22	29.43	29.23	lb.	Time: 11:30 AM
2nd	30.18	29.33	29.14	lb.	Time: 2:00 PM
3rd	_____	_____	_____	lb.	Time: _____

**FIG. X1.1 Example CMU Worksheet**

**ASTM C140 Test Report**  
**Sampling and Testing Concrete Masonry Units and Related Units**

 Job No.: 12-100  
 Report Date: 9/20/2012

 Client: Big Block Plant  
 Address: 111 Block Drive  
 Anytown, USA 12345

 Testing Agency: Accurate Testing Laboratory  
 Address: 123 Main Street  
 Anytown, USA 12345

Standard Specification: ASTM C90-11b

Sampling Party: Big Block Plant

 Unit Description:  
 8 × 8 × 16 Inch  
 Concrete Masonry Unit

Date Samples Received: 9/8/2012

Project Identification: Standard Run

**Summary of Test Results**

Physical Property	ASTM C90-11b Specified Values			ASTM C90-11b Average Test Results		
	Value	Test Results	Units	Value	Test Results	Units
Net Compressive Strength	1900 min	1990	psi	Min. Faceshell Thickness ( $t_{fs}$ )	1.25 min	1.34 in.
Gross Compressive Strength	****	1000	psi	Min. Web Thickness ( $t_w$ )	0.75 min	1.11 in.
Density	****	111.9	pcf	Equivalent Web Thickness	****	2.57 in.
Absorption	15 max	12.5	pcf	Normalized Web Area ( $A_{wn}$ )	6.5 min	28.6 in <sup>2</sup> /ft <sup>2</sup>
Percent Solid	****	50.3	%	Equivalent Thickness	****	3.84 in.
Net Cross-Sectional Area	****	60.01	in. <sup>2</sup>	Max. Var. from Spec. Dimensions	.125 max	0.095 in.
Gross Cross-Sectional Area	****	119.23	in. <sup>2</sup>			

**Individual Unit Test Results**

Compression Units	Specimen No.	Received Weight lb	Cross-Sectional Area*		Max. Load lb	Compressive Strength	
			Gross in <sup>2</sup>	Net in <sup>2</sup>		Gross psi	Net psi
	#1	32.48	119.23	60.01	129770	1090	2160
	#2	31.22	119.23	60.01	113950	960	1900
Date Tested: 9/17/2012	#3	30.92	119.23	60.01	114690	960	1910
	Average	31.54	119.23	60.01	119470	1000	1990

\* Unit areas determined as the average of the three absorption units and are assumed to be the same as those units tested in compression.

Absorption Units	Specimen No.	Avg Width in.	Avg Height in.	Avg Length in.	Avg./Min. Face Shell Thickness in.	Min. Web Thickness in.	Minimum Web Area in. <sup>2</sup>	Normalized Web Area in. <sup>2</sup> /ft <sup>2</sup>
	#5	7.65	7.61	15.62	1.38	1.15	26.18	29.5
Date Tested: 9/10/2012	#6	7.64	7.67	15.63	1.37	1.17	26.83	30.2
	Average	7.64	7.60	15.62	1.34	1.11	25.42	28.6

\*\*Where the thinnest points of opposite face shells differ in thickness by less than 0.125 inches, their measurements are averaged.

Date Tested: 9/17/2012 to 9/19/2012	Specimen No.	Received Weight lb	Immersed Weight lb	Saturated Weight lb	Oven-Dry Weight lb	Absorption pcf	Density pcf	Net Volume ft <sup>3</sup>	Percent Solid %
	#5	31.24	16.22	32.76	29.33	12.9	110.7	0.2651	50.4
	#6	30.90	16.05	32.51	29.14	12.8	110.5	0.2638	49.8
	Average	31.40	16.37	32.85	29.55	12.5	111.9	0.2640	50.3

---

 Signature  
 Laboratory Official

**FIG. X1.2 Example CMU Test Report**



## **X2. TEST REPORT FOR CONCRETE INTERLOCKING PAVING UNITS**

X2.1 Included in this section are two sample test report forms for concrete interlocking paving units (Fig. X2.1 and Fig. X2.2). These samples were developed for use in reporting test information for concrete interlocking paving units to determine their compliance with Specification C936/C936M. These forms meet all of the requirements of A4.6 with the first being for a rectangular paver that does not require and cutting

before testing for compressive strength and the second being for a textured paver that does require cutting to remove the textured surface prior to compressive strength testing. These forms are to be used as guidelines only. Users of these test methods may use or modify these forms to suit their purposes and to address the requirements of the test methods as they apply to the specific specimens being tested.

**ASTM C140-12a Test Report**  
**Sampling and Testing Concrete Masonry Units and Related Units**

 Job No: 12-107  
 Report Date: 9/18/2012

 Client: Big Paver Plant  
 Address: 111 Paver Drive  
 Anytown, USA 12345

 Testing Agency: Accurate Testing Laboratory  
 Address: 123 Main Street  
 Anytown, USA 12345

 Unit Specification: ASTM C936/C936M-11      Sampling Party: Big Paver Plant  
 Unit Description: Concrete Pavers  
 80 mm Holland      Date Samples Received: 9/4/2012

Specified Thickness (mm): 80

 ASTM C140  
 Required for  
 Compressive  
 Strength

**Summary of Test Results**

	ASTM C936		Actual		ASTM C140	
	Required	Actual			Specimen	Actual
Net Area Compressive Strength:	8000 min	8480	psi	Length/Width ( $L_s/W_s$ ):	2.1 max	2.02
Absorption:	5 max	4.7	%	Minimum Aspect Ratio ( $R_a$ ):	0.60 min	0.813
Density (Oven Dry Condition):	****	130.6	pcf	Maximum Aspect Ratio ( $R_a$ ):	1.20 max	0.827
				Average Cap Thickness:	0.060 max	0.034 in.
				Thickness Variation ( $T_c$ ) Across Cut:	Not Cut	Not Cut in.

**Individual Unit Test Results**
*Full Size Unit Measurements*

	Avg. Width (in.)	Avg. Thickness (in.)	Avg. Length (in.)	Sample Weight (lb)
Unit #1	3.852	3.184	7.784	7.360
Unit #2	3.860	3.140	7.768	7.406
Unit #3	3.852	3.172	7.788	7.294
Average	3.855	3.165	7.780	7.353

*Compression Specimens*

Date Tested: 9/6/2012

	Avg. Width $W_s$ (in.)	Avg. Thickness $T_s$ (in.)	Avg. Length $L_s$ (in.)	Variation in		Average Cap Thickness (in.)	Aspect Ratio $R_a$	Aspect Ratio Factor $F_a$	Total Load $P_{max}$ (lb)	Net Area $A_n$ (in <sup>2</sup> )	Net Area Compressive Strength (psi)
				Variation in	After						
				$T_c$ Across Thickness-Reduced Specimen (in.)	Capping Thickness (in.)						
Unit #1	3.852	3.184	7.784	Not Cut	3.252	0.034	0.827	1.159	203720	29.98	7870
Unit #2	3.860	3.140	7.768	Not Cut	3.204	0.032	0.813	1.151	247700	29.98	9510
Unit #3	3.852	3.172	7.788	Not Cut	3.240	0.034	0.823	1.157	209050	30.00	8060
Average	3.855	3.165	7.780	---	3.232	0.033	0.821	1.156	220160	29.99	8480

*Absorption Specimens*

	Received Weight $W_R$ (lb)	Immersed Weight $W_I$ (lb)	SSD Weight $W_S$ (lb)	Oven-Dry Weight $W_D$ (lb)	Absorption (%)	Density (pcf)
Unit #4	7.274	4.082	7.532	7.195	4.7	130.1
Unit #5	7.380	4.138	7.598	7.271	4.5	131.1
Unit #6	7.442	4.224	7.754	7.392	4.9	130.7
Average	7.365	4.148	7.628	7.286	4.7	130.6

 Date Tested:  
 9/8/2012  
 to  
 9/10/2012

 \_\_\_\_\_  
 Signature  
 Laboratory Official

**FIG. X2.1 Sample Test Report Form**



## SUMMARY OF CHANGES

Committee C15 has identified the location of selected changes to this standard since the last issue (C140/C140M – 17b) that may impact the use of this standard. (July 15, 2018)

- (1) Removed 7.1.1 through 7.1.4 and Annex A8 regarding requirements for compressive strength testing machines, and replaced with reference to ASTM **C1716**.
- (2) Modified **A4.3.1.2** to change the minimum aspect ratio for paver specimens to 0.58.

Committee C15 has identified the location of selected changes to this standard since the last issue (C140/C140M – 17a) that may impact the use of this standard. (December 15, 2017)

- (1) Revised **A1.3.1.3**, **A3.4.1**, and **A7.4.1** to clarify that aspect ratio requirements for coupons are targets, and to provide a tolerance on actual dimensions based on those targets.
- (2) The SI versions of the equations in **A1.5.4** and **A2.5.5** were revised to use cubic centimeters as the units for net volume.
- (3) Revised **A3.3.2** to clarify where height measurements are taken.
- (4) Revised **A5.4.1.2** to require a minimum height of coupon specimens for grid pavers, rather than minimum width. Also modified to make coupon dimension ratios targets and provide tolerance for actual dimensions.

Committee C15 has identified the location of selected changes to this standard since the last issue (C140/C140M – 17) that may impact the use of this standard. (June 1, 2017)

- (1) Revised **A1.2.1**, **A2.2.1**, **A3.3.1**, **A4.2.1**, **A5.3.1**, **A6.3.1**, and **A7.3.1** to clarify determination of average values for dimensions.
- (2) Revised **A2.3.1.2** by adding a maximum length requirement for compression specimens of concrete brick.
- (3) Language was added to Annexes **Annex A1**, **Annex A2**, **Annex A3**, **Annex A5**, and **Annex A7** to address measurement of compressive strength coupon specimens.

*ASTM International takes no position respecting the validity of any patent rights asserted in connection with any item mentioned in this standard. Users of this standard are expressly advised that determination of the validity of any such patent rights, and the risk of infringement of such rights, are entirely their own responsibility.*

*This standard is subject to revision at any time by the responsible technical committee and must be reviewed every five years and if not revised, either reapproved or withdrawn. Your comments are invited either for revision of this standard or for additional standards and should be addressed to ASTM International Headquarters. Your comments will receive careful consideration at a meeting of the responsible technical committee, which you may attend. If you feel that your comments have not received a fair hearing you should make your views known to the ASTM Committee on Standards, at the address shown below.*

*This standard is copyrighted by ASTM International, 100 Barr Harbor Drive, PO Box C700, West Conshohocken, PA 19428-2959, United States. Individual reprints (single or multiple copies) of this standard may be obtained by contacting ASTM at the above address or at 610-832-9585 (phone), 610-832-9555 (fax), or [service@astm.org](mailto:service@astm.org) (e-mail); or through the ASTM website ([www.astm.org](http://www.astm.org)). Permission rights to photocopy the standard may also be secured from the Copyright Clearance Center, 222 Rosewood Drive, Danvers, MA 01923, Tel: (978) 646-2600; <http://www.copyright.com/>*