

INSTRUCTION SET OF 8085

Instruction Set of 8085

- An instruction is a binary pattern designed inside a microprocessor to perform a specific function.
- The entire group of instructions that a microprocessor supports is called ***Instruction Set***.
- 8085 has **246** instructions.
- Each instruction is represented by an 8-bit binary value.
- These 8-bits of binary value is called ***Op-Code*** or ***Instruction Byte***.

Classification of Instruction Set

- Data Transfer Instruction
- Arithmetic Instructions
- Logical Instructions
- Branching Instructions
- Control Instructions

Data Transfer Instructions

- These instructions move data between registers, or between memory and registers.
- These instructions copy data from source to destination.
- While copying, the contents of source are not modified.

Data Transfer Instructions

Opcode	Operand	Description
MOV	Rd, Rs Rd, M M, Rs	Copy from source to destination.

- This instruction copies the contents of the source register into the destination register.
- The contents of the source register are not altered.
- If one of the operands is a memory location, its location is specified by the contents of the HL registers.
- **Example:** MOV B, C
- MOV B, M
- MOV M, C

Data Transfer Instructions

Opcode	Operand	Description
MVI	Rd, Data M, Data	Move immediate 8-bit

- The 8-bit data is stored in the destination register or memory.
- If the operand is a memory location, its location is specified by the contents of the H-L registers.
- **Example:** MVI A, 57H
- MVI M, 57H

Data Transfer Instructions

Opcode	Operand	Description
LXI	Reg. pair, 16-bit data	Load register pair immediate

- This instruction loads 16-bit data in the register pair.
- **Example:** LXI H, 2034 H

Data Transfer Instructions

Opcode	Operand	Description
LDA	16-bit address	Load Accumulator

- The contents of a memory location, specified by a 16-bit address in the operand, are copied to the accumulator.
- The contents of the source are not altered.
- **Example:** LDA 2034H

Data Transfer Instructions

Opcode	Operand	Description
LDAX	B/D Register Pair	Load accumulator indirect

- The contents of the designated register pair point to a memory location.
- This instruction copies the contents of that memory location into the accumulator.
- The contents of either the register pair or the memory location are not altered.
- **Example:** LDAX B

Data Transfer Instructions

Opcode	Operand	Description
LHLD	16-bit address	Load H-L registers direct

- This instruction copies the contents of memory location pointed out by 16-bit address into register L.
- It copies the contents of next memory location into register H.
- **Example:** LHLD 2040 H

Data Transfer Instructions

Opcode	Operand	Description
STA	16-bit address	Store accumulator direct

- The contents of accumulator are copied into the memory location specified by the operand.
- **Example:** STA 2500 H

Data Transfer Instructions

Opcode	Operand	Description
STAX	Reg. pair	Store accumulator indirect

- The contents of accumulator are copied into the memory location specified by the contents of the register pair.
- **Example: STAX B**

Data Transfer Instructions

Opcode	Operand	Description
SHLD	16-bit address	Store H-L registers direct

- The contents of register L are stored into memory location specified by the 16-bit address.
- The contents of register H are stored into the next memory location.
- **Example:** SHLD 2550 H

Data Transfer Instructions

Opcode	Operand	Description
XCHG	None	Exchange H-L with D-E

- The contents of register H are exchanged with the contents of register D.
- The contents of register L are exchanged with the contents of register E.
- **Example:** XCHG

Arithmetic Instructions

- These instructions perform the operations like:
 - Addition
 - Subtract
 - Increment
 - Decrement

Addition

- Any 8-bit number, or the contents of register, or the contents of memory location can be added to the contents of accumulator.
- The result (sum) is stored in the accumulator.
- No two other 8-bit registers can be added directly.
- **Example:** The contents of register B cannot be added directly to the contents of register C.

Subtraction

- Any 8-bit number, or the contents of register, or the contents of memory location can be subtracted from the contents of accumulator.
- The result is stored in the accumulator.
- Subtraction is performed in 2's complement form.
- If the result is negative, it is stored in 2's complement form.
- No two other 8-bit registers can be subtracted directly.

Increment / Decrement

- The 8-bit contents of a register or a memory location can be incremented or decremented by 1.
- The 16-bit contents of a register pair can be incremented or decremented by 1.
- Increment or decrement can be performed on any register or a memory location.

Arithmetic Instructions

Opcode	Operand	Description
ADD	R M	Add register or memory to accumulator

- The contents of register or memory are added to the contents of accumulator.
- The result is stored in accumulator.
- If the operand is memory location, its address is specified by H-L pair.
- All flags are modified to reflect the result of the addition.
- **Example:** ADD B or ADD M

Arithmetic Instructions

Opcode	Operand	Description
ADC	R M	Add register or memory to accumulator with carry

- The contents of register or memory and Carry Flag (CY) are added to the contents of accumulator.
- The result is stored in accumulator.
- If the operand is memory location, its address is specified by H-L pair.
- All flags are modified to reflect the result of the addition.
- **Example:** ADC B or ADC M

Arithmetic Instructions

Opcode	Operand	Description
ADI	8-bit data	Add immediate to accumulator

- The 8-bit data is added to the contents of accumulator.
- The result is stored in accumulator.
- All flags are modified to reflect the result of the addition.
- **Example:** ADI 45 H

Arithmetic Instructions

Opcode	Operand	Description
ACI	8-bit data	Add immediate to accumulator with carry

- The 8-bit data and the Carry Flag (CY) are added to the contents of accumulator.
- The result is stored in accumulator.
- All flags are modified to reflect the result of the addition.
- **Example:** ACI 45 H

Arithmetic Instructions

Opcode	Operand	Description
DAD	Reg. pair	Add register pair to H-L pair

- The 16-bit contents of the register pair are added to the contents of H-L pair.
- The result is stored in H-L pair.
- If the result is larger than 16 bits, then CY is set.
- No other flags are changed.
- **Example:** DAD B

Arithmetic Instructions

Opcode	Operand	Description
SUB	R M	Subtract register or memory from accumulator

- The contents of the register or memory location are subtracted from the contents of the accumulator.
- The result is stored in accumulator.
- If the operand is memory location, its address is specified by H-L pair.
- All flags are modified to reflect the result of subtraction.
- **Example:** SUB B or SUB M

Arithmetic Instructions

Opcode	Operand	Description
SBB	R M	Subtract register or memory from accumulator with borrow

- The contents of the register or memory location and Borrow Flag (i.e. CY) are subtracted from the contents of the accumulator.
- The result is stored in accumulator.
- If the operand is memory location, its address is specified by H-L pair.
- All flags are modified to reflect the result of subtraction.
- **Example:** SBB B or SBB M

Arithmetic Instructions

Opcode	Operand	Description
SUI	8-bit data	Subtract immediate from accumulator

- The 8-bit data is subtracted from the contents of the accumulator.
- The result is stored in accumulator.
- All flags are modified to reflect the result of subtraction.
- **Example:** SUI 45 H

Arithmetic Instructions

Opcode	Operand	Description
SBI	8-bit data	Subtract immediate from accumulator with borrow

- The 8-bit data and the Borrow Flag (i.e. CY) is subtracted from the contents of the accumulator.
- The result is stored in accumulator.
- All flags are modified to reflect the result of subtraction.
- **Example:** SBI 45 H

Arithmetic Instructions

Opcode	Operand	Description
INR	R M	Increment register or memory by 1

- The contents of register or memory location are incremented by 1.
- The result is stored in the same place.
- If the operand is a memory location, its address is specified by the contents of H-L pair.
- **Example:** INR B or INR M

Arithmetic Instructions

Opcode	Operand	Description
INX	R	Increment register pair by 1

- The contents of register pair are incremented by 1.
- The result is stored in the same place.
- **Example:** INX H

Arithmetic Instructions

Opcode	Operand	Description
DCR	R M	Decrement register or memory by 1

- The contents of register or memory location are decremented by 1.
- The result is stored in the same place.
- If the operand is a memory location, its address is specified by the contents of H-L pair.
- **Example:** DCR B or DCR M

Arithmetic Instructions

Opcode	Operand	Description
DCX	R	Decrement register pair by 1

- The contents of register pair are decremented by 1.
- The result is stored in the same place.
- **Example:** DCX H

Logical Instructions

- These instructions perform logical operations on data stored in registers, memory and status flags.
- The logical operations are:
 - AND
 - OR
 - XOR
 - Rotate
 - Compare
 - Complement

AND, OR, XOR

- Any 8-bit data, or the contents of register, or memory location can logically have
 - AND operation
 - OR operation
 - XOR operation
- with the contents of accumulator.
- The result is stored in accumulator.

Rotate

- Each bit in the accumulator can be shifted either left or right to the next position.

Compare

- Any 8-bit data, or the contents of register, or memory location can be compares for:
 - Equality
 - Greater Than
 - Less Than
- with the contents of accumulator.
- The result is reflected in status flags.

Complement

- The contents of accumulator can be complemented.
- Each 0 is replaced by 1 and each 1 is replaced by 0.

Logical Instructions

Opcode	Operand	Description
CMP	R M	Compare register or memory with accumulator

- The contents of the operand (register or memory) are compared with the contents of the accumulator.
- Both contents are preserved .
- The result of the comparison is shown by setting the flags of the PSW as follows:

Logical Instructions

Opcode	Operand	Description
CMP	R M	Compare register or memory with accumulator

- if $(A) < (\text{reg/mem})$: carry flag is set
- if $(A) = (\text{reg/mem})$: zero flag is set
- if $(A) > (\text{reg/mem})$: carry and zero flags are reset.
- **Example:** CMP B or CMP M

Logical Instructions

Opcode	Operand	Description
CPI	8-bit data	Compare immediate with accumulator

- The 8-bit data is compared with the contents of accumulator.
- The values being compared remain unchanged.
- The result of the comparison is shown by setting the flags of the PSW as follows:

Logical Instructions

Opcode	Operand	Description
CPI	8-bit data	Compare immediate with accumulator

- if $(A) < \text{data}$: carry flag is set
- if $(A) = \text{data}$: zero flag is set
- if $(A) > \text{data}$: carry and zero flags are reset
- **Example:** CPI 89H

Logical Instructions

Opcode	Operand	Description
ANA	R M	Logical AND register or memory with accumulator

- The contents of the accumulator are logically ANDed with the contents of register or memory.
- The result is placed in the accumulator.
- If the operand is a memory location, its address is specified by the contents of H-L pair.
- S, Z, P are modified to reflect the result of the operation.
- CY is reset and AC is set.
- **Example:** ANA B or ANA M.

Logical Instructions

Opcode	Operand	Description
ANI	8-bit data	Logical AND immediate with accumulator

- The contents of the accumulator are logically ANDed with the 8-bit data.
- The result is placed in the accumulator.
- S, Z, P are modified to reflect the result.
- CY is reset, AC is set.
- **Example:** ANI 86H.

Logical Instructions

Opcode	Operand	Description
XRA	R M	Exclusive OR register or memory with accumulator

- The contents of the accumulator are XORed with the contents of the register or memory.
- The result is placed in the accumulator.
- If the operand is a memory location, its address is specified by the contents of H-L pair.
- S, Z, P are modified to reflect the result of the operation.
- CY and AC are reset.
- **Example:** XRA B or XRA M.

Logical Instructions

Opcode	Operand	Description
ORA	R M	Logical OR register or memory with accumulator

- The contents of the accumulator are logically ORed with the contents of the register or memory.
- The result is placed in the accumulator.
- If the operand is a memory location, its address is specified by the contents of H-L pair.
- S, Z, P are modified to reflect the result.
- CY and AC are reset.
- **Example:** ORA B or ORA M.

Logical Instructions

Opcode	Operand	Description
ORI	8-bit data	Logical OR immediate with accumulator

- The contents of the accumulator are logically ORed with the 8-bit data.
- The result is placed in the accumulator.
- S, Z, P are modified to reflect the result.
- CY and AC are reset.
- **Example:** ORI 86H.

Logical Instructions

Opcode	Operand	Description
XRA	R M	Logical XOR register or memory with accumulator

- The contents of the accumulator are XORed with the contents of the register or memory.
- The result is placed in the accumulator.
- If the operand is a memory location, its address is specified by the contents of H-L pair.
- S, Z, P are modified to reflect the result of the operation.
- CY and AC are reset.
- **Example:** XRA B or XRA M.

Logical Instructions

Opcode	Operand	Description
XRI	8-bit data	XOR immediate with accumulator

- The contents of the accumulator are XORed with the 8-bit data.
- The result is placed in the accumulator.
- S, Z, P are modified to reflect the result.
- CY and AC are reset.
- **Example:** XRI 86H.

Logical Instructions

Opcode	Operand	Description
RLC	None	Rotate accumulator left

- Each binary bit of the accumulator is rotated left by one position.
- Bit D7 is placed in the position of D0 as well as in the Carry flag.
- CY is modified according to bit D7.
- S, Z, P, AC are not affected.
- **Example:** RLC.

Logical Instructions

Opcode	Operand	Description
RRC	None	Rotate accumulator right

- Each binary bit of the accumulator is rotated right by one position.
- Bit D0 is placed in the position of D7 as well as in the Carry flag.
- CY is modified according to bit D0.
- S, Z, P, AC are not affected.
- **Example:** RRC.

Logical Instructions

Opcode	Operand	Description
RAL	None	Rotate accumulator left through carry

- Each binary bit of the accumulator is rotated left by one position through the Carry flag.
- Bit D7 is placed in the Carry flag, and the Carry flag is placed in the least significant position D0.
- CY is modified according to bit D7.
- S, Z, P, AC are not affected.
- **Example:** RAL.

Logical Instructions

Opcode	Operand	Description
RAR	None	Rotate accumulator right through carry

- Each binary bit of the accumulator is rotated right by one position through the Carry flag.
- Bit D0 is placed in the Carry flag, and the Carry flag is placed in the most significant position D7.
- CY is modified according to bit D0.
- S, Z, P, AC are not affected.
- **Example:** RAR.

Logical Instructions

Opcode	Operand	Description
CMA	None	Complement accumulator

- The contents of the accumulator are complemented.
- No flags are affected.
- **Example: CMA.**

Logical Instructions

Opcode	Operand	Description
CMC	None	Complement carry

- The Carry flag is complemented.
- No other flags are affected.
- **Example: CMC.**

Logical Instructions

Opcode	Operand	Description
STC	None	Set carry

- The Carry flag is set to 1.
- No other flags are affected.
- **Example: STC.**

Branching Instructions

- The branching instruction alter the normal sequential flow.
- These instructions alter either unconditionally or conditionally.

Branching Instructions

Opcode	Operand	Description
JMP	16-bit address	Jump unconditionally

- The program sequence is transferred to the memory location specified by the 16-bit address given in the operand.
- **Example:** JMP 2034 H.

Branching Instructions

Opcode	Operand	Description
Jx	16-bit address	Jump conditionally

- The program sequence is transferred to the memory location specified by the 16-bit address given in the operand based on the specified flag of the PSW.
- **Example:** JZ 2034 H.

Jump Conditionally

Opcode	Description	Status Flags
JC	Jump if Carry	CY = 1
JNC	Jump if No Carry	CY = 0
JP	Jump if Positive	S = 0
JM	Jump if Minus	S = 1
JZ	Jump if Zero	Z = 1
JNZ	Jump if No Zero	Z = 0
JPE	Jump if Parity Even	P = 1
JPO	Jump if Parity Odd	P = 0

Branching Instructions

Opcode	Operand	Description
CALL	16-bit address	Call unconditionally

- The program sequence is transferred to the memory location specified by the 16-bit address given in the operand.
- Before the transfer, the address of the next instruction after CALL (the contents of the program counter) is pushed onto the stack.
- **Example:** CALL 2034 H.

Branching Instructions

Opcode	Operand	Description
Cx	16-bit address	Call conditionally

- The program sequence is transferred to the memory location specified by the 16-bit address given in the operand based on the specified flag of the PSW.
- Before the transfer, the address of the next instruction after the call (the contents of the program counter) is pushed onto the stack.
- **Example:** CZ 2034 H.

Call Conditionally

Opcode	Description	Status Flags
CC	Call if Carry	CY = 1
CNC	Call if No Carry	CY = 0
CP	Call if Positive	S = 0
CM	Call if Minus	S = 1
CZ	Call if Zero	Z = 1
CNZ	Call if No Zero	Z = 0
CPE	Call if Parity Even	P = 1
CPO	Call if Parity Odd	P = 0

Branching Instructions

Opcode	Operand	Description
RET	None	Return unconditionally

- The program sequence is transferred from the subroutine to the calling program.
- The two bytes from the top of the stack are copied into the program counter, and program execution begins at the new address.
- **Example:** RET.

Branching Instructions

Opcode	Operand	Description
Rx	None	Call conditionally

- The program sequence is transferred from the subroutine to the calling program based on the specified flag of the PSW.
- The two bytes from the top of the stack are copied into the program counter, and program execution begins at the new address.
- **Example:** RZ.

Return Conditionally

Opcode	Description	Status Flags
RC	Return if Carry	CY = 1
RNC	Return if No Carry	CY = 0
RP	Return if Positive	S = 0
RM	Return if Minus	S = 1
RZ	Return if Zero	Z = 1
RNZ	Return if No Zero	Z = 0
RPE	Return if Parity Even	P = 1
RPO	Return if Parity Odd	P = 0

Branching Instructions

Opcode	Operand	Description
RST	0 – 7	Restart (Software Interrupts)

- The RST instruction jumps the control to one of eight memory locations depending upon the number.
- These are used as software instructions in a program to transfer program execution to one of the eight locations.
- **Example:** RST 3.

Restart Address Table

Instructions	Restart Address
RST 0	0000 H
RST 1	0008 H
RST 2	0010 H
RST 3	0018 H
RST 4	0020 H
RST 5	0028 H
RST 6	0030 H
RST 7	0038 H

Control Instructions

- The control instructions control the operation of microprocessor.

Control Instructions

Opcode	Operand	Description
NOP	None	No operation

- No operation is performed.
- The instruction is fetched and decoded but no operation is executed.
- **Example:** NOP

Control Instructions

Opcode	Operand	Description
HLT	None	Halt

- The CPU finishes executing the current instruction and halts any further execution.
- An interrupt or reset is necessary to exit from the halt state.
- **Example: HLT**

Control Instructions

Opcode	Operand	Description
DI	None	Disable interrupt

- The interrupt enable flip-flop is reset and all the interrupts except the TRAP are disabled.
- No flags are affected.
- **Example:** DI

Control Instructions

Opcode	Operand	Description
EI	None	Enable interrupt

- The interrupt enable flip-flop is set and all interrupts are enabled.
- No flags are affected.
- This instruction is necessary to re-enable the interrupts (except TRAP).
- **Example:** EI

Control Instructions

Opcode	Operand	Description
RIM	None	Read Interrupt Mask

- This is a multipurpose instruction used to read the status of interrupts 7.5, 6.5, 5.5 and read serial data input bit.
- The instruction loads eight bits in the accumulator with the following interpretations.
- **Example:** RIM

RIM Instruction

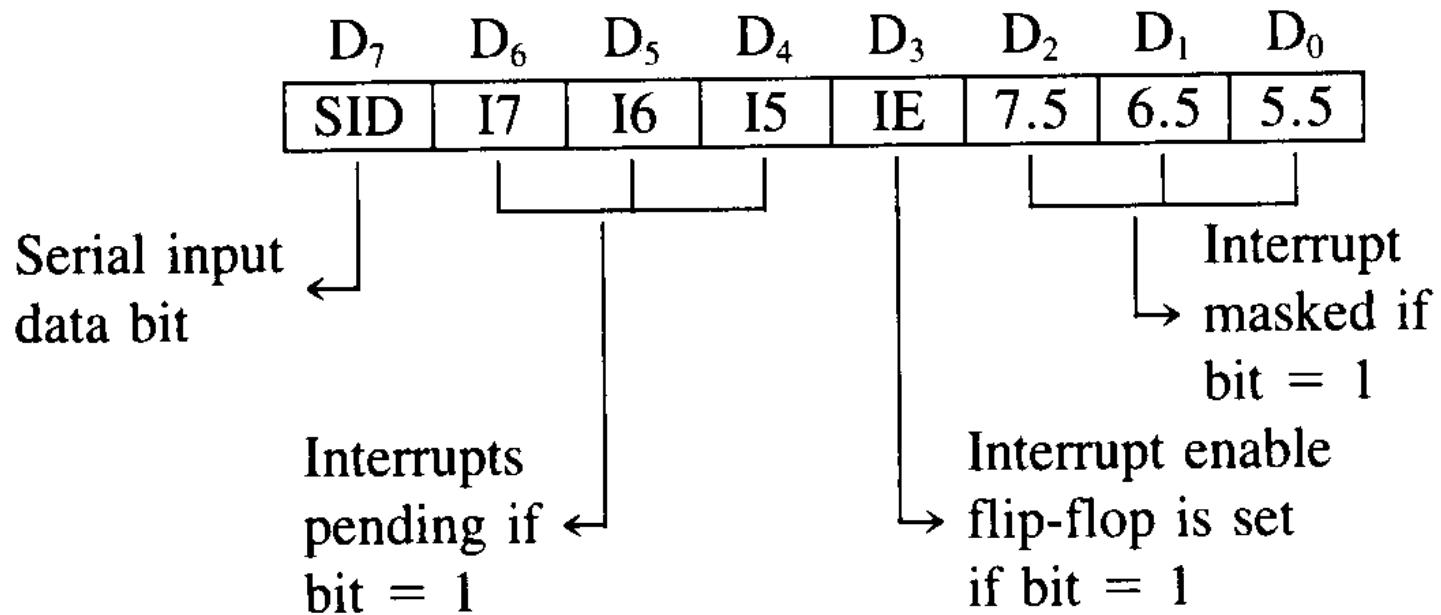

Control Instructions

Opcode	Operand	Description
SIM	None	Set Interrupt Mask

- This is a multipurpose instruction and used to implement the 8085 interrupts 7.5, 6.5, 5.5, and serial data output.
- The instruction interprets the accumulator contents as follows.
- **Example: SIM**

SIM Instruction

