

Tishk International University  
Mechatronics Engineering Department  
Electrical Circuits Analysis II  
Code: ME-114  
Lecture 5: 24/05 /2022



# **AC Electrical Circuits Analysis:**

## **AC Fundamentals II**

**Instructor: Safa Anmar Albarwary**

**Email: [safa.anmar@tiu.edu.iq](mailto:safa.anmar@tiu.edu.iq)**

# Objectives

After completing this module, you should be able to:

- Describe the sinusoidal variation in ac current and voltage, and calculate their effective values.
- Write and apply equations for calculating the inductive and capacitive reactance for inductors and capacitors in an ac circuit.
- Describe, with diagrams and equations, the phase relationships for circuits containing resistance, capacitance, and inductance.
- Write and apply equations for calculating the impedance, the phase angle, the effective current, the average power, and the resonant frequency for a series ac circuit.
- Describe the basic operation of a step-up and a step-down transformer.
- Write and apply the transformer equation and determine the efficiency of a transformer.

# Alternating Currents

An alternating current such as that produced by a generator has no direction in the sense that direct current has. The magnitudes vary sinusoidally with time as given by:

AC-voltage and  
current

$$E = E_{\max} \sin \theta$$

$$i = i_{\max} \sin \theta$$

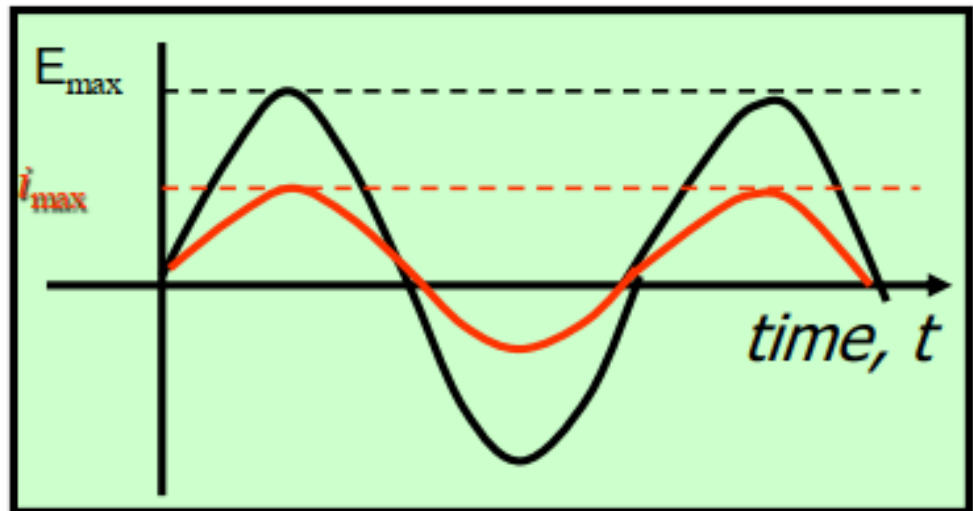

# Effective (RMS) Values

- While instantaneous, peak, and average values provide useful information about a waveform, none of them truly represents the ability of the waveform to do useful work.
- The concept of waveform's **effective value** is an important one; in practice, most ac voltages and currents are expressed as effective values. Effective values are also called **rms values**.
- An effective value is an equivalent dc value: it tells you how many volts or amps of dc that a time-varying waveform is equal to in terms of its ability to produce average power.
- Effective values depend on the waveform. In North America its value is 120 Vac. This means that the sinusoidal voltage at the wall outlets of your home is capable of producing the same average power as 120 volts of steady dc.
- RMS is the effective value of sinusoids, and that's why the rms value called effective value at the same time.

# Effective Values – Root Mean Square (RMS)

- The rms value relates **dc and ac** quantities with respect to the power delivered to a load.

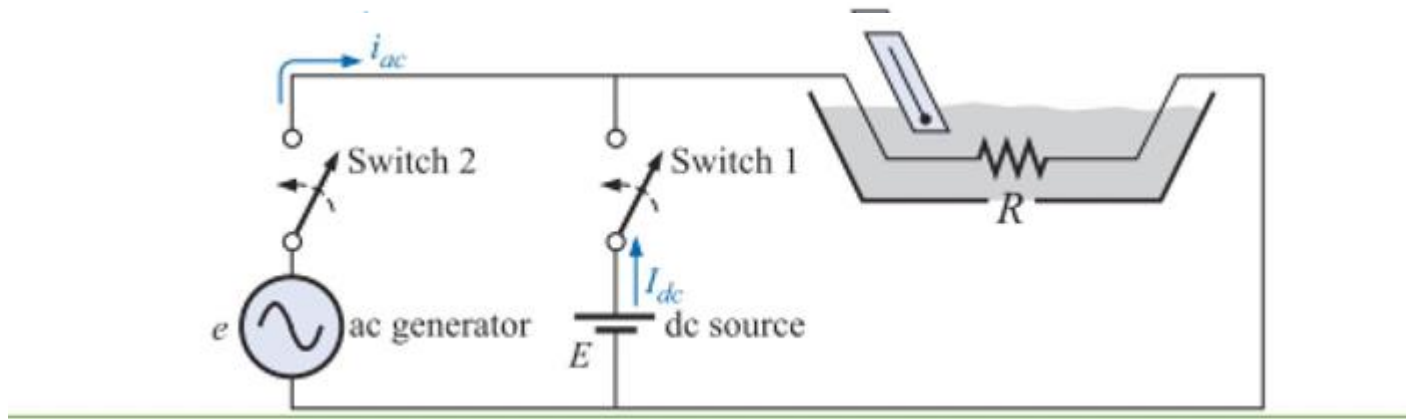

- An **effective (rms) value** is an equivalent dc value:
  - ✓ it tells you how many volts of dc that a time-varying waveform is equal to in terms of its ability to produce average power.

For DC case,  
since  $I$  is constant, the power is constant also.

$$P_{\text{avg}} = P = I^2 R$$

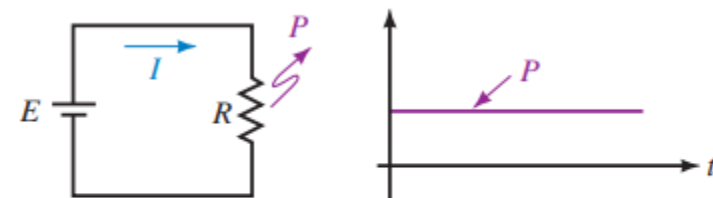

$P = I^2 R$ . Therefore,  $P$  is constant.

(b) dc Circuit

# Effective Values – Root Mean Square (RMS)

For AC case,

A sketch of  $p(t)$  is shown in Figure, obtained by squaring values of current at various points along the axis, then multiplying by  $R$ .

$$\begin{aligned} p(t) &= i^2 R \\ &= (I_m \sin \omega t)^2 R = I_m^2 R \sin^2 \omega t \\ &= I_m^2 R \left[ \frac{1}{2} (1 - \cos 2\omega t) \right] \end{aligned}$$

$$P_{\text{avg}} = P = I^2 R$$

$$I^2 = \frac{I_m^2}{2}$$

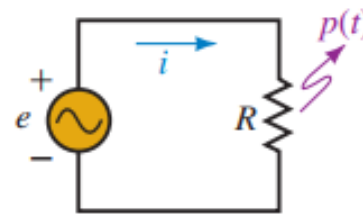

$p(t) = i^2 R$ . Therefore,  $p(t)$  varies cyclically.

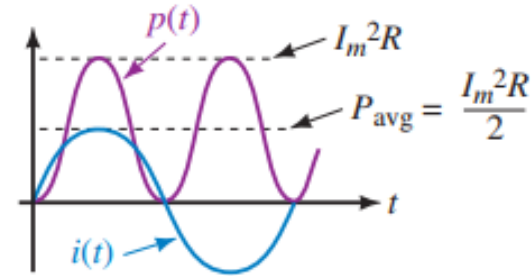

(a) ac Circuit

Now take the square root of both sides. Thus,

$$I = \sqrt{\frac{I_m^2}{2}} = \frac{I_m}{\sqrt{2}} = 0.707 I_m$$

Determining the effective value of sinusoidal ac.

Current  $I$  is the value that we are looking for; it is the effective value of current  $i$ . To emphasize that it is an effective value, we will initially use subscripted notation  $I_{\text{eff}}$ . Thus,

$$I_{\text{eff}} = \frac{I_m}{\sqrt{2}} = 0.707 I_m$$

Effective values for voltage are found in the same way:

$$E_{\text{eff}} = \frac{E_m}{\sqrt{2}} = 0.707 E_m$$

## Example,

Determine the effective values of

a.  $i = 10 \sin \omega t$  A

b.  $i = 50 \sin(\omega t + 20^\circ)$  mA

c.  $v = 100 \cos 2\omega t$  V

**Solution** Since effective values depend only on magnitude,

a.  $I_{\text{eff}} = (0.707)(10 \text{ A}) = 7.07 \text{ A}$

b.  $I_{\text{eff}} = (0.707)(50 \text{ mA}) = 35.35 \text{ mA}$

c.  $V_{\text{eff}} = (0.707)(100 \text{ V}) = 70.7 \text{ V}$

# General Equation for Effective Values

- The  $\sqrt{2}$  relationship holds only for sinusoidal waveforms. For other waveforms, you need a more general formula. Using calculus, it can be shown that for any waveform

$$I_{\text{eff}} = \sqrt{\frac{1}{T} \int_0^T i^2 dt} \quad \dots (1)$$

- with a similar equation for voltage. This equation can be used to compute effective values for any waveform, including sinusoidal. In addition, it leads to a graphic approach to finding effective values. In the equation, the integral of  $i^2$  represents the area under the  $i^2$  waveform. Thus,

$$I_{\text{eff}} = \sqrt{\frac{\text{area under the } i^2 \text{ curve}}{\text{base}}} \quad \dots (2)$$

- To compute effective values using this equation, do the following:  
**Step 1:** Square the current (or voltage) curve.  
**Step 2:** Find the area under the squared curve.  
**Step 3:** Divide the area by the length of the curve.  
**Step 4:** Find the square root of the value from Step 3

General equation for effective value,

**Example**, determine the effective value for the following waveform.

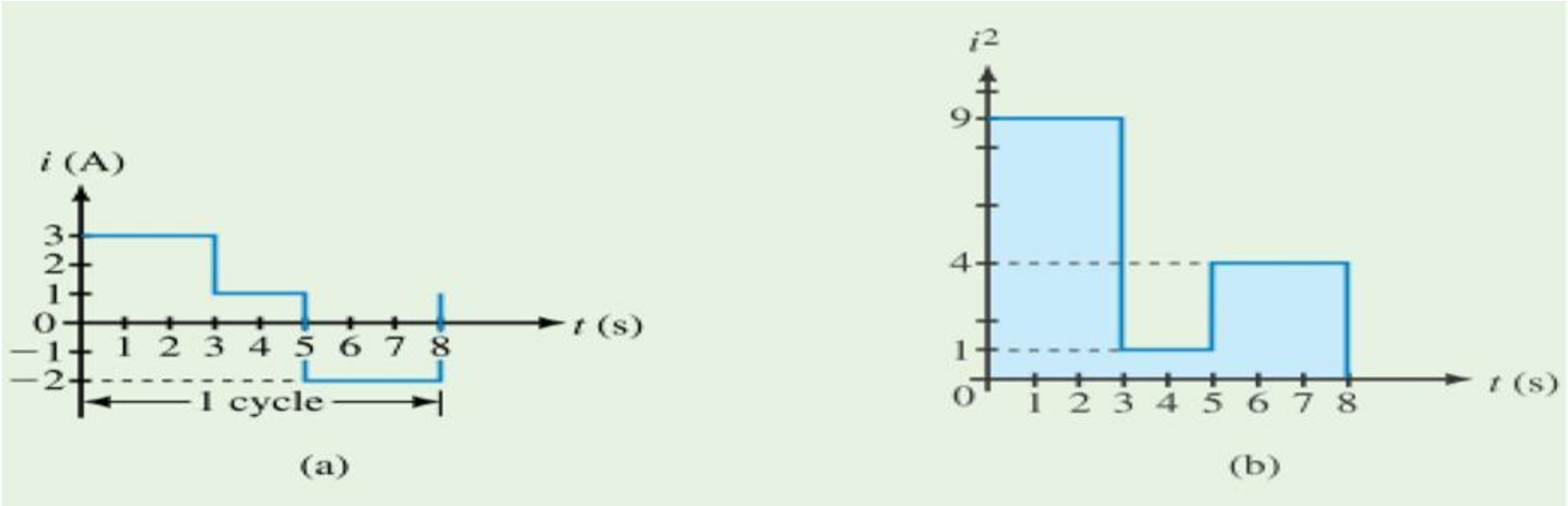

**Solution** Square the curve, then apply Equation 15–30. Thus,

$$I_{\text{eff}} = \sqrt{\frac{(9 \times 3) + (1 \times 2) + (4 \times 3)}{8}}$$
$$= \sqrt{\frac{41}{8}} = 2.26 \text{ A}$$

# Class Activity,

One cycle of a voltage waveform is shown in Figure 15–65(a). Determine its effective (rms) value.

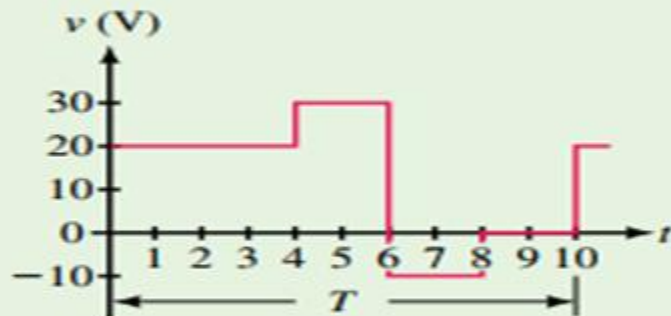

(a) Voltage waveform

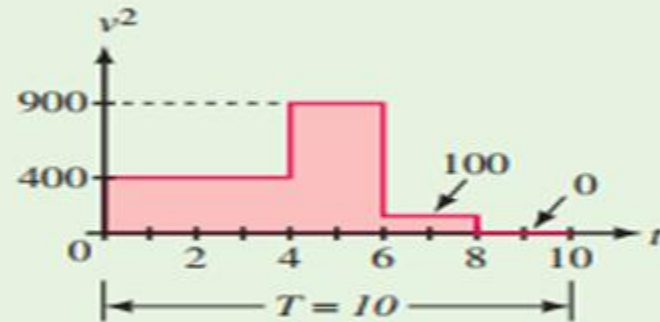

(b) Squared waveform

FIGURE 15–65

**Solution** Square the voltage waveform point by point, and plot it as in (b). Apply Equation 15–30:

$$\begin{aligned} V_{\text{eff}} &= \sqrt{\frac{(400 \times 4) + (900 \times 2) + (100 \times 2) + (0 \times 2)}{10}} \\ &= \sqrt{\frac{3600}{10}} = 19.0 \text{ V} \end{aligned}$$

Thus, the waveform of Figure 15–65(a) has the same effective value as 19.0 V of steady dc.

# Effective AC Current

The average current in a cycle is zero—half + and half -.

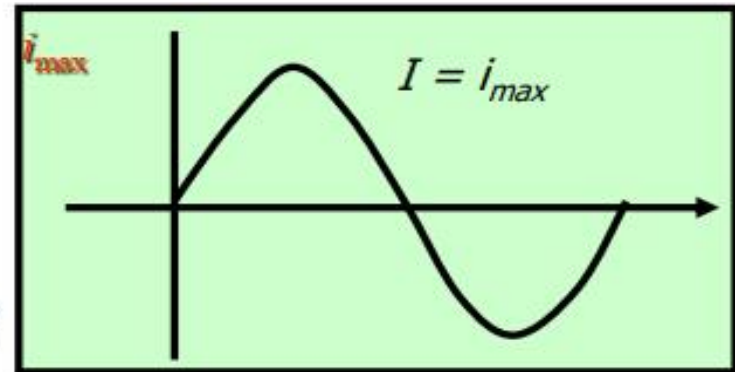

But energy is expended, regardless of direction. So the "root-mean-square" value is useful.



$$I_{rms} = \sqrt{\frac{I^2}{2}} = \frac{I}{0.707}$$

The **rms** value  $I_{rms}$  is sometimes called the **effective** current  $I_{eff}$ .

The effective ac current:

$$i_{eff} = 0.707 i_{max}$$

# Effective AC definitions

The average current in a cycle is zero—half + and half -.

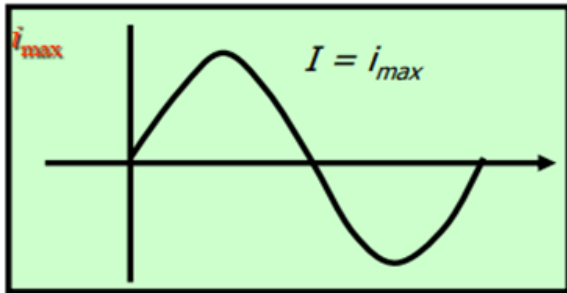

But energy is expended, regardless of direction. So the "root-mean-square" value is useful.

$$I_{rms} = \sqrt{\frac{I^2}{2}} = \frac{I}{0.707}$$

The rms value  $I_{rms}$  is sometimes called the effective current  $I_{eff}$ .

One effective ampere is that ac current for which the power is the same as for one ampere of dc current.

Effective Current :  $I_{eff} = 0.707 I_{max}$

One effective volt is that ac voltage that gives an effective ampere through a resistance of one ohm.

Effective Voltage :  $V_{eff} = 0.707 V_{max}$

## Example,

For a particular device, the house ac voltage is 120V and the ac current is 10A.  
WHAT ARE THEIR MAX. VALUES?

$$I_{eff.} = 0.707 I_{max}$$

$$I_{max} = 14.14 A$$

$$V_{eff.} = 0.707 V_{max}$$

$$V_{max} = 170 V$$

The ac voltage actually varies from **+170 V** to **-170 V** and the current from **14.1 A** to **-14.1 A**.

# R, L, AND C ELEMENTS AND THE IMPEDANCE CONCEPT

- Till now we learned how to analyze a few simple AC circuits in the time domain using voltages and currents expressed as functions of time. However, this is not a very practical approach. A more practical approach is to represent AC voltages and currents as **phasors** and circuit elements as **impedances**, and to analyze circuits in the phasor domain using complex algebra.
- With this approach, ac circuit analysis is handled much like dc circuit analysis, and all basic relationships and theorems—Ohm's law, Kirchhoff's laws, mesh and nodal analysis, superposition, and so on—apply.
- The major difference is that ac quantities are complex numbers, rather than real numbers, as with dc. While this complicates computational details, it does not alter basic circuit principles.
- Since phasor analysis and the impedance concept require a familiarity with complex numbers, we begin with a short review.

## REMEMBER: Phasor,

- A phasor is a rotating line whose projection on a vertical axis can be used to represent sinusoidally varying quantities.

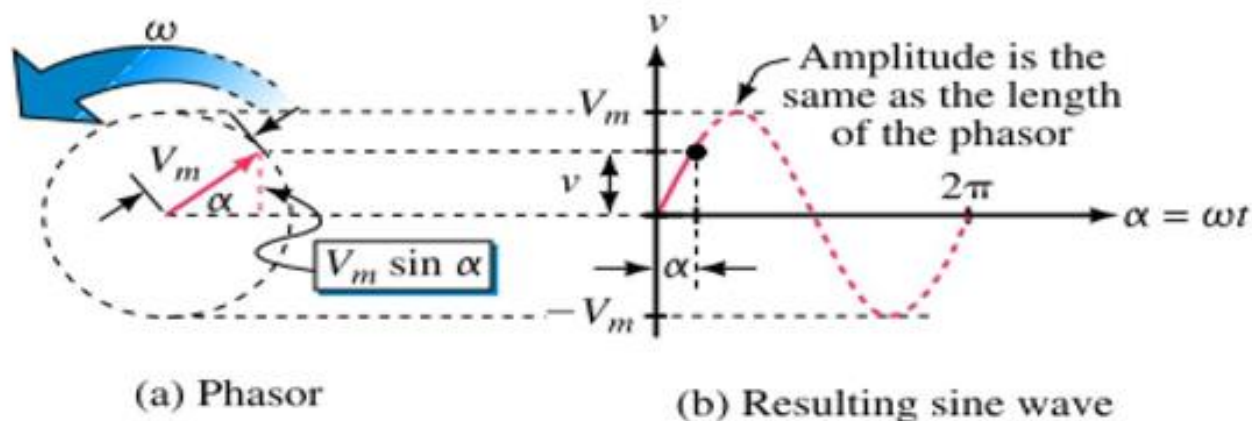

As the phasor rotates about the origin, its vertical projection creates a sine wave.

- A phasor is a complex number that represents the amplitude and phase of a sinusoid.
- This representation of phasors provides a simple mean of analyzing linear

# Complex Numbers

## Geometrical Representation ,

A **complex number** is a number of the form  $C = a + jb$ , where  $a$  and  $b$  are real numbers and  $j = \sqrt{-1}$ . The number  $a$  is called the **real** part of  $C$  and  $b$  is called its **imaginary** part. (In circuit theory,  $j$  is used to denote the imaginary component rather than  $i$  to avoid confusion with current  $i$ .)

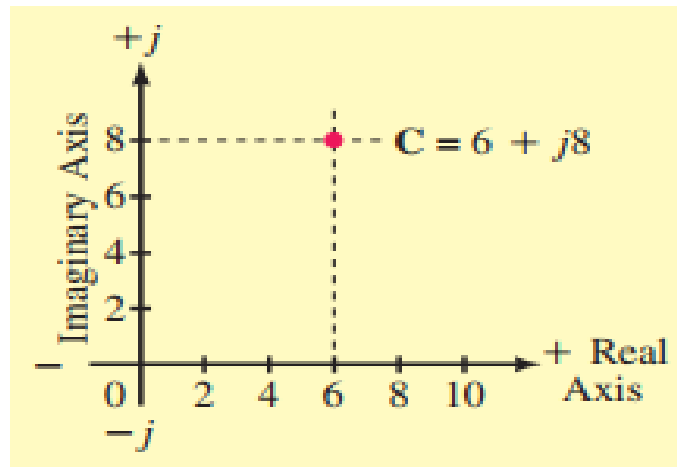

A complex number in rectangular form.

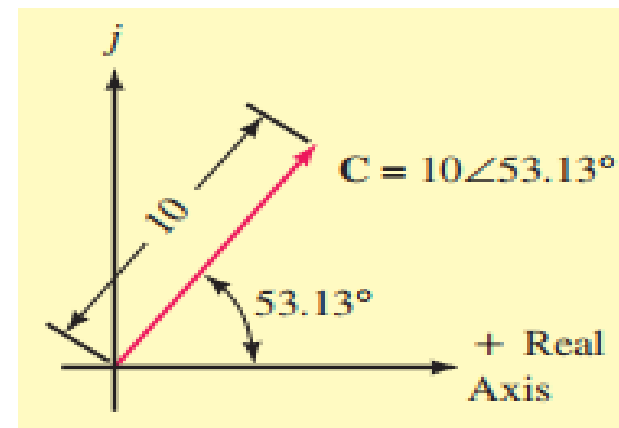

A complex number in polar form.

# Complex Numbers in Rectangular Form

## Addition and Subtraction of Complex Numbers,

$$A = x + jy \quad B = w + jz$$

$$A + B = (x + w) + j(y + z)$$

$$A - B = (x - w) + j(y - z)$$

**Example,** Two vectors are defined as,  $A = 4 + j1$  and  $B = 2 + j3$  respectively. Determine the sum and difference of the two vectors in both rectangular ( $a + jb$ ) form and graphically as an Argand Diagram.

$$A + B = (4 + j1) + (2 + j3)$$

$$A - B = (4 + j1) - (2 + j3)$$

$$A + B = (4 + 2) + j(1 + 3) = 6 + j4$$

$$A - B = (4 - 2) + j(1 - 3) = 2 - j2$$

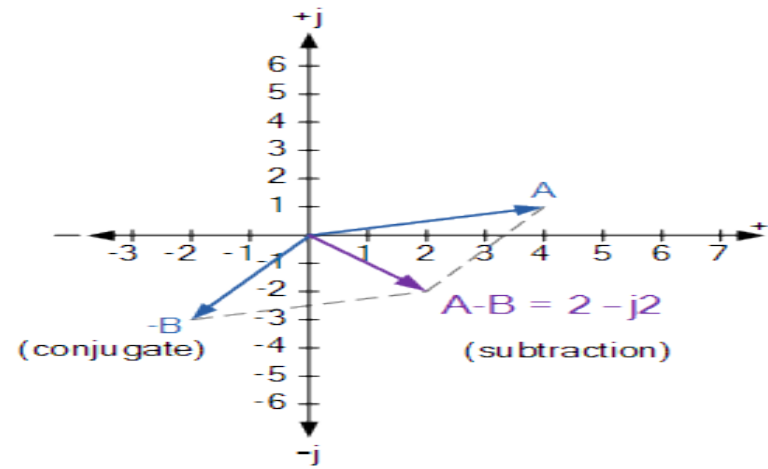
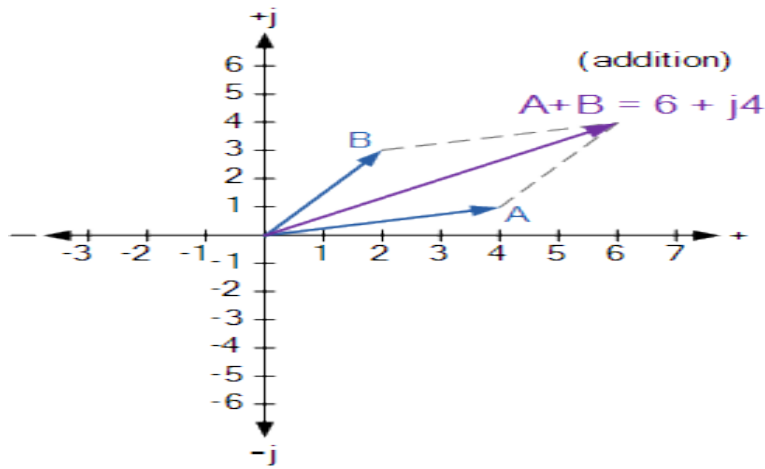

## Multiplication and Division of Complex Numbers,

The multiplication of complex numbers in the rectangular form follows more or less the same rules as for normal algebra along with some additional rules for the successive multiplication of the j-operator where:  $j^2 = -1$ . So for example, multiplying together the two vectors of  $A = 4 + j1$  and  $B = 2 + j3$  will give the following result:

$$\begin{aligned} A \times B &= (4 + j1)(2 + j3) \\ &= 8 + j12 + j2 + j^2 3 \end{aligned}$$

$$\text{but } j^2 = -1,$$

$$= 8 + j14 - 3$$

$$A \times B = 5 + j14$$

## Multiplication and Division of Complex Numbers,

- Mathematically, the division of complex numbers in rectangular form is a little more difficult to perform as it requires the use of the denominators conjugate function to convert the denominator of the equation into a real number. This is called “ratio-nalising”.
- Then the division of complex numbers is best carried out using “Polar Form”, which we will explain in the coming slides. However, as an example in rectangular form lets find the value of vector A divided by vector B.

$$\frac{A}{B} = \frac{4 + j1}{2 + j3}$$

Multiply top & bottom by Conjugate of  $2 + j3$

$$\frac{4 + j1}{2 + j3} \times \frac{2 - j3}{2 - j3} = \frac{8 - j12 + j2 - j^2 3}{4 - j6 + j6 - j^2 9}$$

$$= \frac{8 - j10 + 3}{4 + 9} = \frac{11 - j10}{13}$$

$$= \frac{11}{13} + \frac{-j10}{13} = 0.85 - j0.77$$

# Complex Numbers using Polar Form

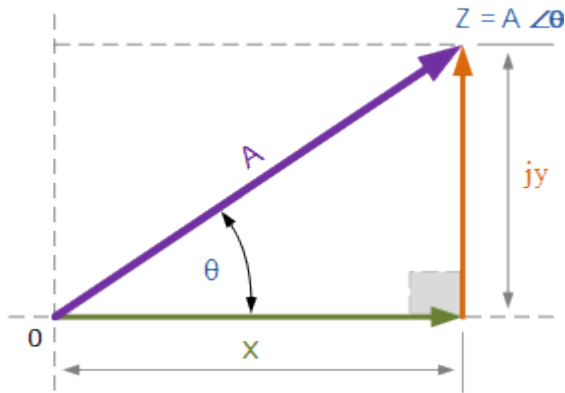

$$A^2 = x^2 + y^2$$

$$A = \sqrt{x^2 + y^2}$$

$$\theta = \tan^{-1} \frac{y}{x}$$

Also,  $x = A \cdot \cos\theta$ ,  $y = A \cdot \sin\theta$

## Converting Polar Form into Rectangular Form, ( P → R )

$$6 \angle 30^\circ = x + jy$$

However,

$$x = A \cdot \cos\theta \quad y = A \cdot \sin\theta$$

Therefore,

$$\begin{aligned} 6 \angle 30^\circ &= (6 \cos\theta) + j(6 \sin\theta) \\ &= (6 \cos 30^\circ) + j(6 \sin 30^\circ) \\ &= (6 \times 0.866) + j(6 \times 0.5) \\ &= 5.2 + j3 \end{aligned}$$

## Converting Rectangular Form into Polar Form, ( R → P )

$$(5.2 + j3) = A \angle \theta$$

where:  $A = \sqrt{5.2^2 + 3^2} = 6$

and  $\theta = \tan^{-1} \frac{3}{5.2} = 30^\circ$

Hence,  $(5.2 + j3) = 6 \angle 30^\circ$

## Polar Form Multiplication and Division,

Rectangular form is best for adding and subtracting complex numbers as we saw above, but polar form is often better for multiplying and dividing. To multiply together two vectors in polar form, we must first multiply together the two modulus or magnitudes and then add together their angles.

### Multiplication in Polar Form:

$$Z_1 \times Z_2 = A_1 \times A_2 \angle \theta_1 + \theta_2$$

Multiplying together  $6 \angle 30^\circ$  and  $8 \angle -45^\circ$  in polar form gives us.

$$Z_1 \times Z_2 = 6 \times 8 \angle 30^\circ + (-45^\circ) = 48 \angle -15^\circ$$

### Division in Polar Form:

Likewise, to divide together two vectors in polar form, we must divide the two modulus and then subtract their angles as shown.

$$\frac{Z_1}{Z_2} = \left( \frac{A_1}{A_2} \right) \angle \theta_1 - \theta_2$$

## Summery: Phasor,

➤ A complex number  $z$  can be represented as:

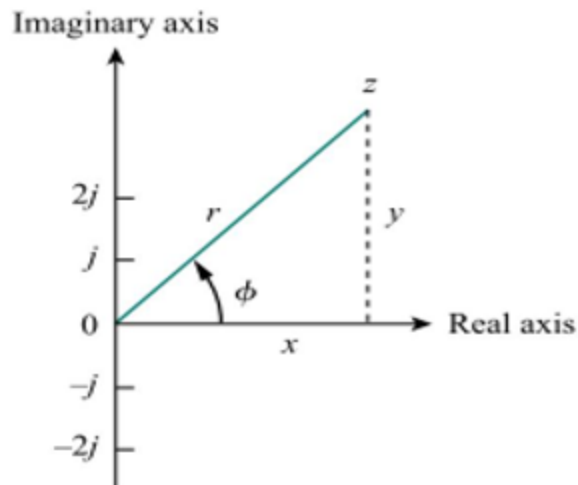

$$z = x + jy$$

Rectangular Form

$$z = r \angle \phi$$

Polar Form

$$z = r e^{j\phi}$$

Exponential Form

$$r = \sqrt{x^2 + y^2}, \quad \phi = \tan^{-1} \frac{y}{x}$$

➤ On the other hand, if we know  $r$  and  $\phi$ , we can obtain  $x$  and  $y$  as:

$$x = r \cos \phi, \quad y = r \sin \phi$$

# Summery: Phasor,

## ➤ Important Operations:

### **Addition:**

$$z_1 + z_2 = (x_1 + x_2) + j(y_1 + y_2)$$

### **Subtraction:**

$$z_1 - z_2 = (x_1 - x_2) + j(y_1 - y_2)$$

### **Multiplication:**

$$z_1 z_2 = r_1 r_2 \angle \phi_1 + \phi_2$$

### **Division:**

$$\frac{z_1}{z_2} = \frac{r_1}{r_2} \angle \phi_1 - \phi_2$$

# Complex Numbers in ac Analysis

$$\mathbf{E} = E_m \angle \theta$$

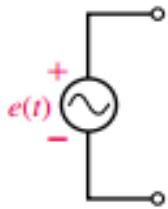

(a)  $e(t) = E_m \sin(\omega t + \theta)$

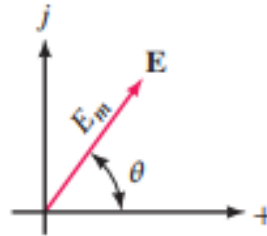

(b)  $\mathbf{E} = E_m \angle \theta$

Representation of a sinusoidal source voltage as a complex number.

From this point of view, the sinusoidal voltage  $e(t) = 200 \sin(\omega t + 40^\circ)$  of Figure (a) and (b) can be represented by its phasor equivalent,  $\mathbf{E} = 200 \text{ V} \angle 40^\circ$ , as in (c).



(a)  $e = 200 \sin(\omega t + 40^\circ) \text{ V}$

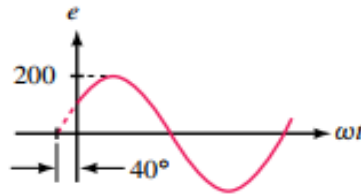

(b) Waveform

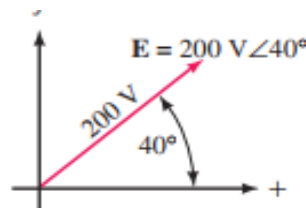

(c) Phasor equivalent

Transforming  $e = 200 \sin(\omega t + 40^\circ) \text{ V}$  to  $\mathbf{E} = 200 \text{ V} \angle 40^\circ$ .

## NOTES...

1. As you saw in Chapter 15, the basic definition of a phasor is a rotating radius vector with a length equal to the amplitude ( $E_m$  or  $I_m$ ) of the voltage or current that it represents. In practice, however, phasor voltages and phasor currents are always

expressed as rms values. We will make this change shortly; in the meantime, there are a few ideas that we need to explore using the phasor's fundamental definition.

2. Quantities expressed as time functions are said to be in the *time domain*, while quantities expressed as phasors are said to be in the *phasor domain*. Thus,  $e = 200 \sin(\omega t + 40^\circ)$  is in the time domain, while its phasor equivalent  $\mathbf{E} = 200 \text{ V} \angle 40^\circ$  is in the phasor domain.

3. The phasor domain is sometimes referred to as the *frequency domain*.

## Example, (H.W or Class Activity):

Given  $e_1 = 10 \sin \omega t$  V and  $e_2 = 15 \sin(\omega t + 60^\circ)$  V as before, determine  $v$  and sketch it.

Answer,

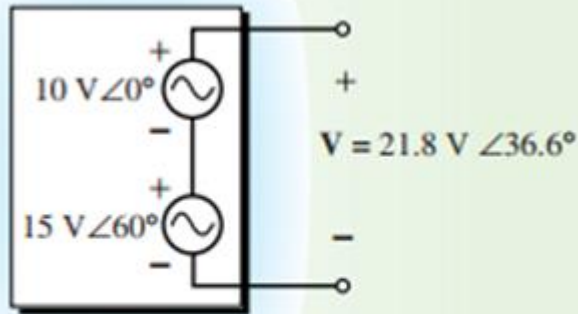

(a) Phasor summation

$e_1 = 10 \sin \omega t$  V. Thus,  $E_1 = 10 \text{ V} \angle 0^\circ$ .

$e_2 = 15 \sin(\omega t + 60^\circ)$  V. Thus,  $E_2 = 15 \text{ V} \angle 60^\circ$ .

Hint,

Note that  $v(t)$ , determined from phasor  $V$  gives the same result as adding  $e_1$  and  $e_2$  point by point.

# Representing Phasors as RMS Values

## NOTES...

1. Although we use phasors to represent sinusoidal waveforms, it should be noted that sine waves and phasors are not the same thing. Sinusoidal voltages and currents are real—they are the actual quantities that you measure with meters and whose waveforms you see on oscilloscopes. *Phasors, on the other hand, are mathematical abstractions that we use to help visualize relationships and solve problems.*
2. To add or subtract sinusoidal voltages or currents, follow the three steps outlined in Example 16–7. That is,
  - convert sine waves to phasors and express them in complex number form,
  - add or subtract the complex numbers,
  - convert back to time functions if desired.

## Example,

Express the voltage and current of Figure 16–10 in both the time and the phasor domains. (Remember to use rms values in the phasor domain.)

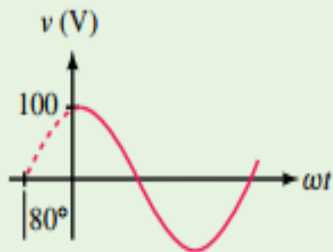

(a)

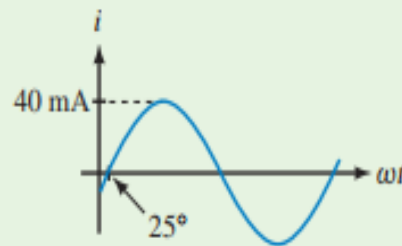

(b)

## Solution

a. Time domain:  $v = 100 \sin(\omega t + 80^\circ)$  volts.

Phasor domain:  $\mathbf{V} = (0.707)(100 \text{ V} \angle 80^\circ) = 70.7 \text{ V} \angle 80^\circ$  (rms).

b. Time domain:  $i = 40 \sin(\omega t - 25^\circ)$  mA.

Phasor domain:  $\mathbf{I} = (0.707)(40 \text{ mA} \angle -25^\circ) = 28.3 \text{ mA} \angle -25^\circ$  (rms).