

**Tishk International University**  
**Engineering Faculty**  
**Petroleum and Mining Department**



# **Petroleum Production Engineering I**

## **Lecture 6: Skin Factor Estimation**

**4<sup>th</sup>-Grade- Fall Semester 2023-2024**

Instructor: Nabaz Ali  
nabaz.ali@tiu.edu.iq

# Content

- Formation damage near wellbore
- Damage skin – Drilling
- Damage skin – Cementing
- Damage skin – Completion
- Damage skin – Injection
- Damage skin – Production
- Hawkins' Formula
- Skin Components
- Skin due to partial completions
- Skin Factor in horizontal well

# Introduction

**Skin Factor:** A numerical value used to analytically model the difference from the pressure drop predicted by Darcy's law due to skin. Typical values for the skin factor range from -6 for an infinite-conductivity massive hydraulic fracture to more than 100 for a poorly executed gravel pack.

The skin factor is defined to characterize the well condition and the degree of communication between the well and the reservoir.

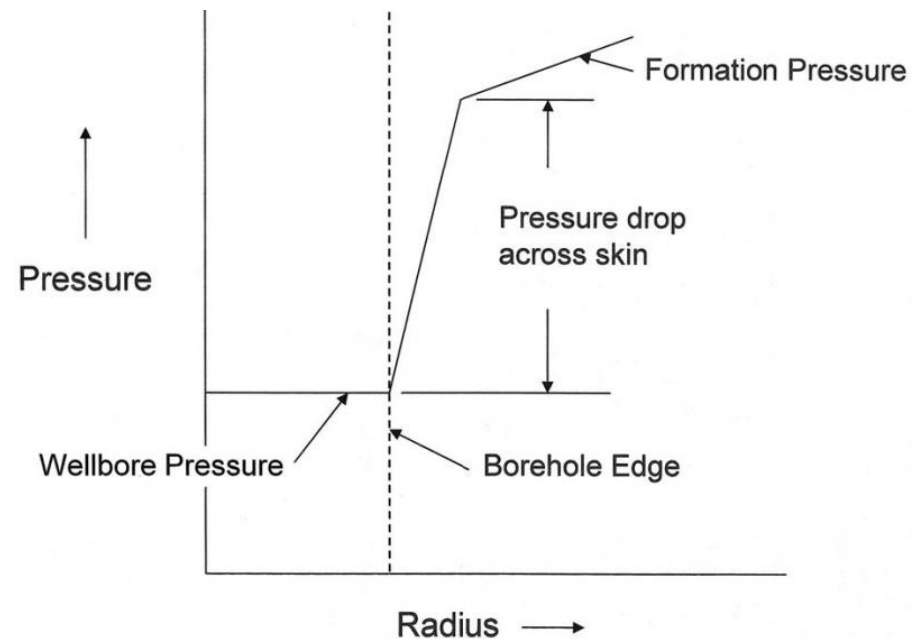

# Well Damage characterization

- **Damaged Well: Skin factor  $> 0$** 
  - A flow restriction is present between the well and the reservoir, with an increase in pressure drop. The poor connection between the well and reservoir could be due to some insufficient or plugged perforations, some mud invasion, partial penetration, etc.
  - A large positive skin can represent an opportunity to increase the production rate or decrease the drawdown. Well treatments such as new perforations, acidification or hydraulic fracturing could be performed to reduce the skin factor and improved the near wellbore area.
- **Stimulated Well: Skin factor  $< 0$** 
  - In this case, the flow conditions are improved near the wellbore and the pressure drop is reduced.
  - Some small negative skin values can be explained by the well geometry, acidification, or the presence of some natural fractures in the reservoir. Large negative skin values are created by hydraulic fractures

# Damage Skin

- Drilling
- Cementing
- Completion
- Injection
- Production

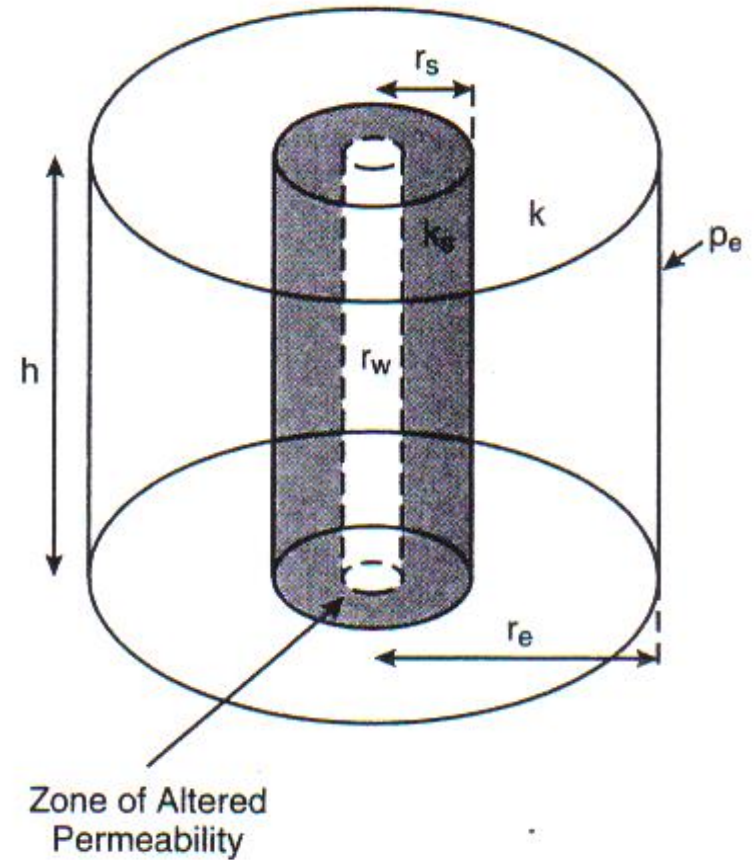

# Damage Skin - Drilling

- Drilling mud invasion
- Long exposure to drilling mud
- Improper drilling mud
- High pressure difference

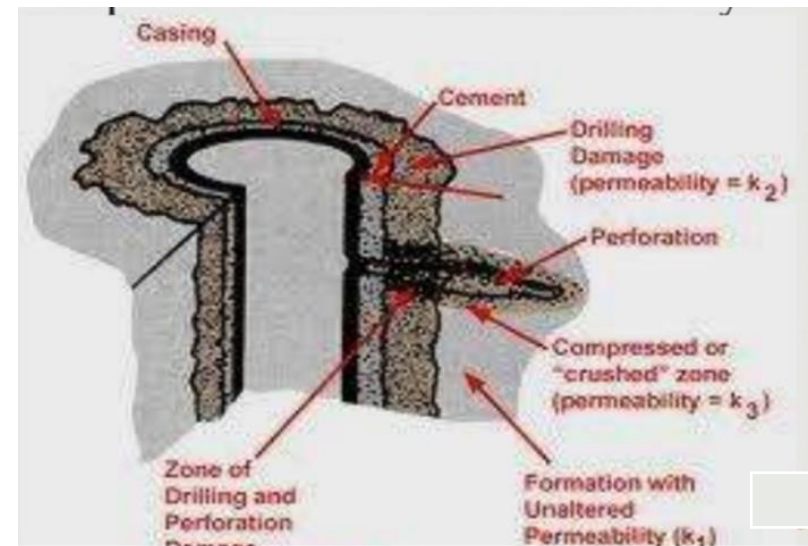

# Damage Skin - Cementing

- Cement filtrate
- Improper completion fluid
- Low quality cementing → repeat cementing

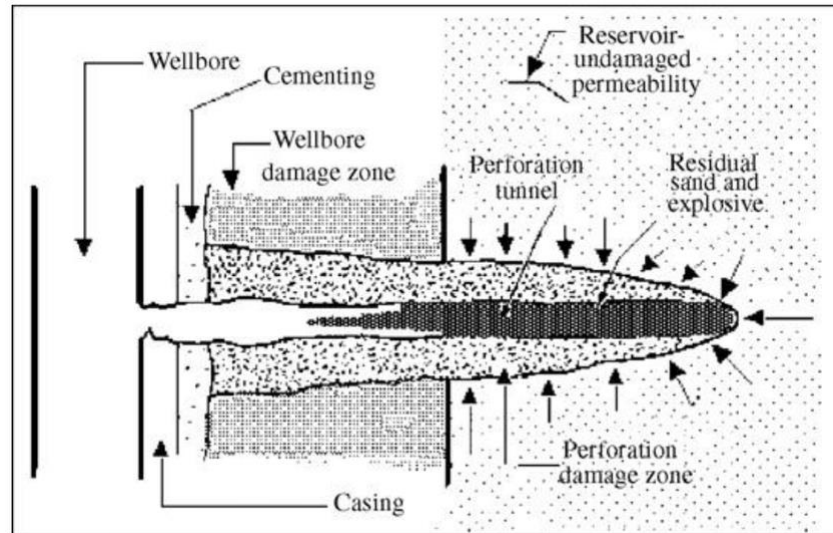

# Damage Skin - Completion

- Perforation (mechanical damage)
- Improper completion fluid
- Overbalance perforation
- Improper stimulation fluid

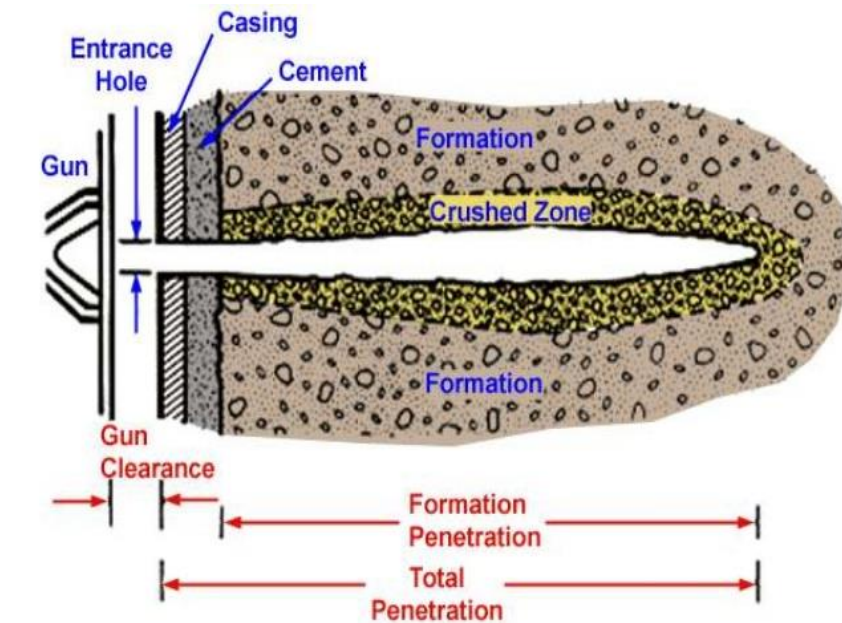

# Damage Skin - Production

- High velocity (high production rate) causes fines migrate and causes damage.

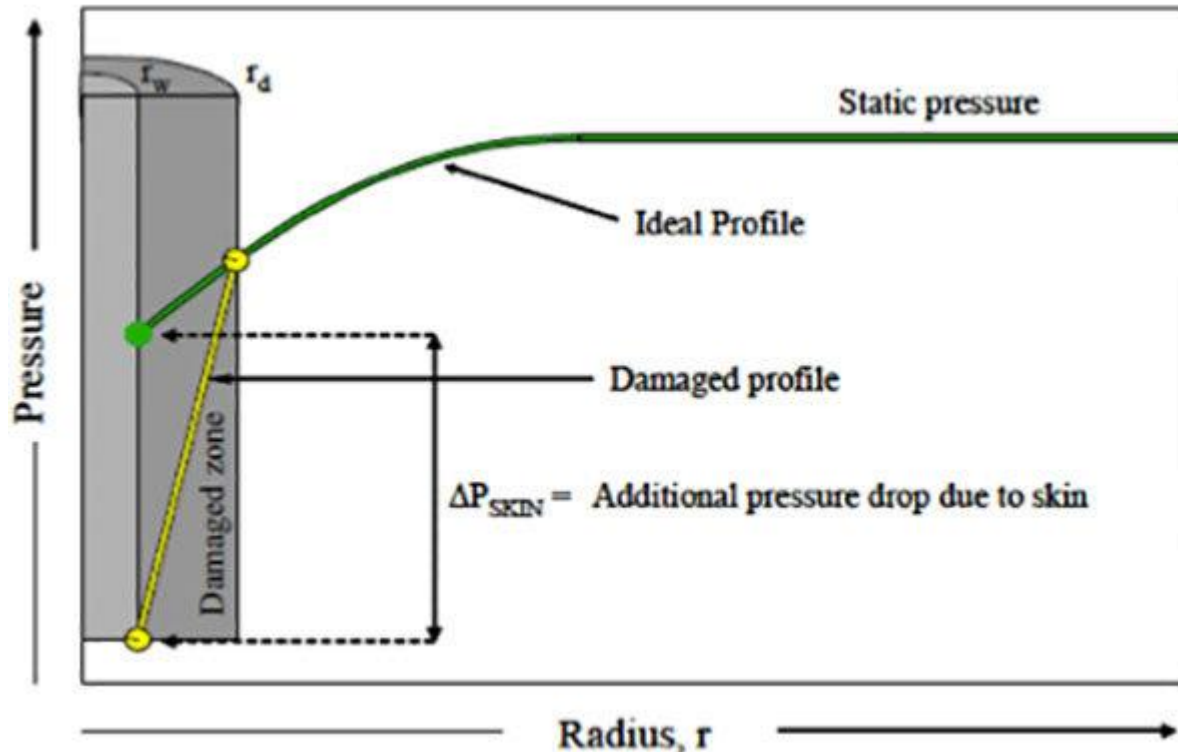

# Damage Skin - Injection

- High injection velocity (high injection rate) because fines migrate
- Improper injection fluid properties (chemical reaction, emulsion)
- Solid in injection fluid

# Wellbore damage

**External source  
and original  
particles migrate**

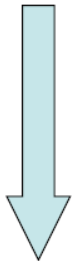

**Particle plugging  
of pore spaces**

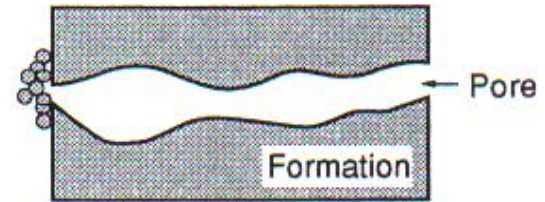

Cake Formation by Large Particles

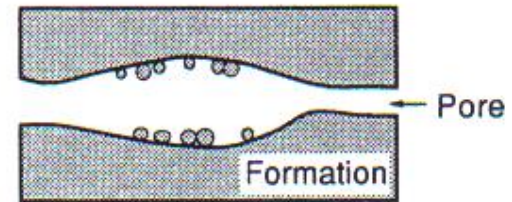

Surface Deposits of Adhering Particles

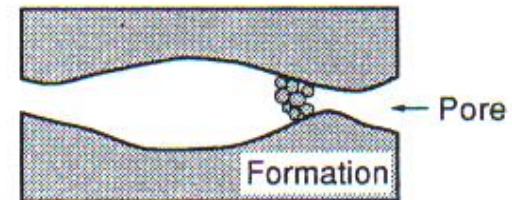

Plugging Type Deposits

# Wellbore damage

## Fines migrate caused by water flow

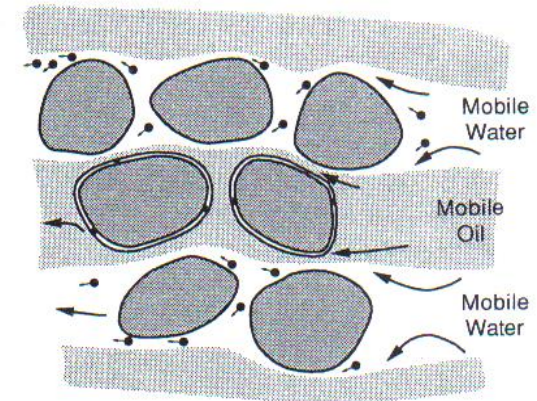
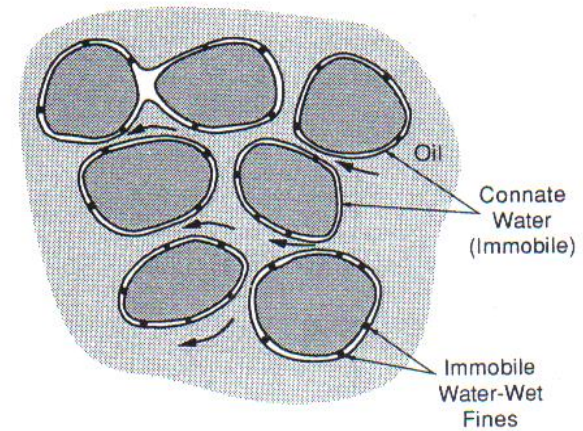

# Skin Factor

Using a two-region reservoir model, Hawkins clarified the concept of skin.

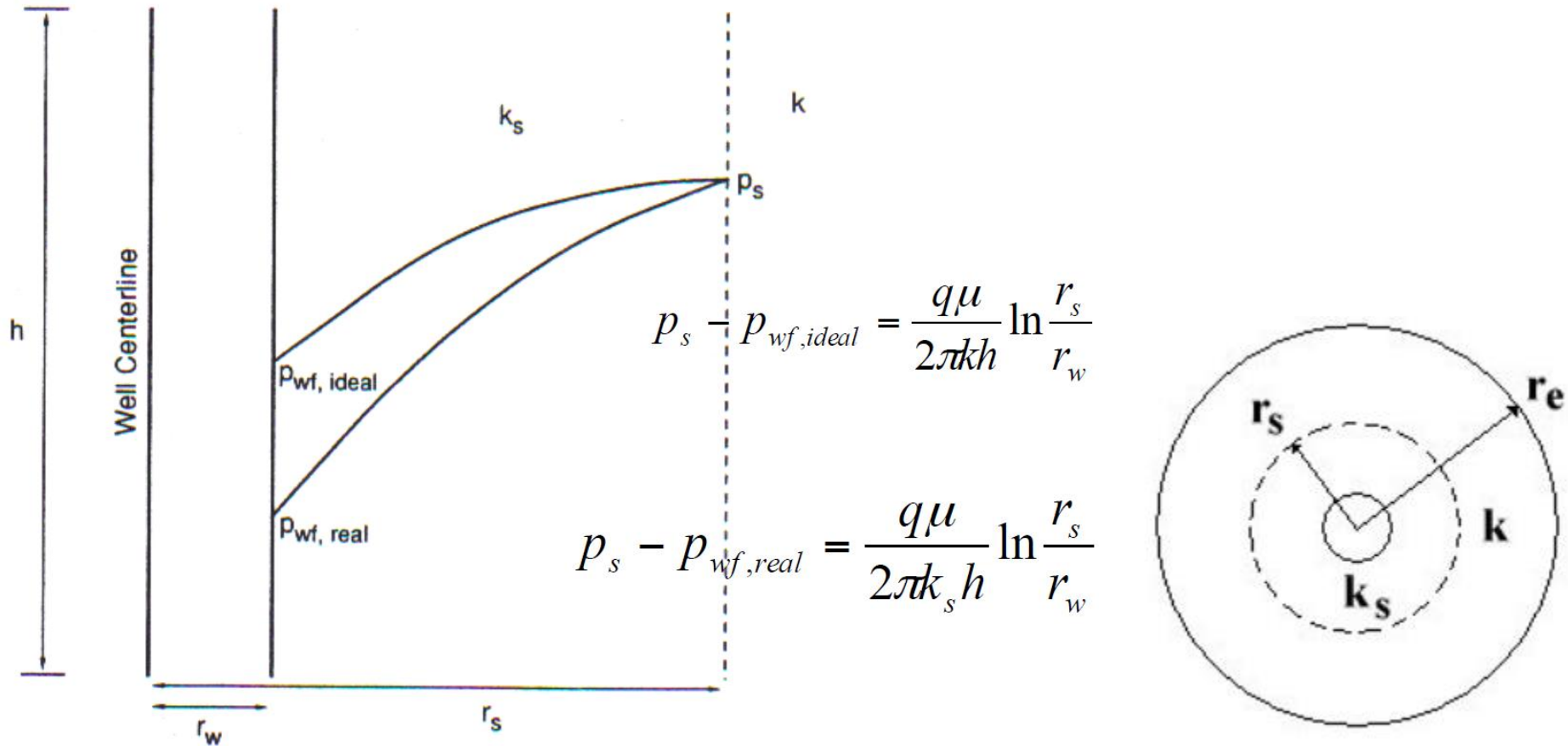

# Hawkins' Formula

$$\Delta p = P_{wf,ideal} - P_{wf,real} = \frac{q\mu}{2\pi k_s h} \ln \frac{r_s}{r_w} - \frac{q\mu}{2\pi kh} \ln \frac{r_s}{r_w}$$

$$= \frac{q\mu}{2\pi h} \left( \frac{1}{k_s} - \frac{1}{k} \right) \ln \frac{r_s}{r_w} = \frac{q\mu}{2\pi kh} \left( \frac{k}{k_s} - 1 \right) \ln \frac{r_s}{r_w}$$

$$= \frac{q\mu}{2\pi kh} S$$

$$S = \left( \frac{k}{k_s} - 1 \right) \ln \frac{r_s}{r_w}$$

# Permeability in Damaged Zone

- Permeability in the damaged zone is not constant

$$s = k \int_{r_w}^{r_s} \frac{dr}{rk_s(r)} - \ln \frac{r_s}{r_w}$$

Or

$$\bar{k}_s = \frac{\ln \frac{r_s}{r_w}}{\int_{r_w}^{r_s} \frac{dr}{rk_s(r)}}$$

# Skin Components

- The skin effect is attributed to not only formation damage but all the near wellbore conditions that deviate from the homogeneous radial flow.
- Skin factor considers the lumped effects of all the non-ideal conditions

# Skin Components

$$S = S_d + S_{c+\theta} + S_p + \sum S_{pseudo}$$

$S_d$  = damage skin

$S_{c+\theta}$  = skin due to partial completion and slant

$S_p$  = perforation skin

$S_{pseudo}$  = pseudo skins from rate - depend, phase - depend, and converging skin effects

# Skin due to partial completion and slant

- Bad perforation job or poor gravel pack placement
- Misguided effort to retard or avoid gas or water coning

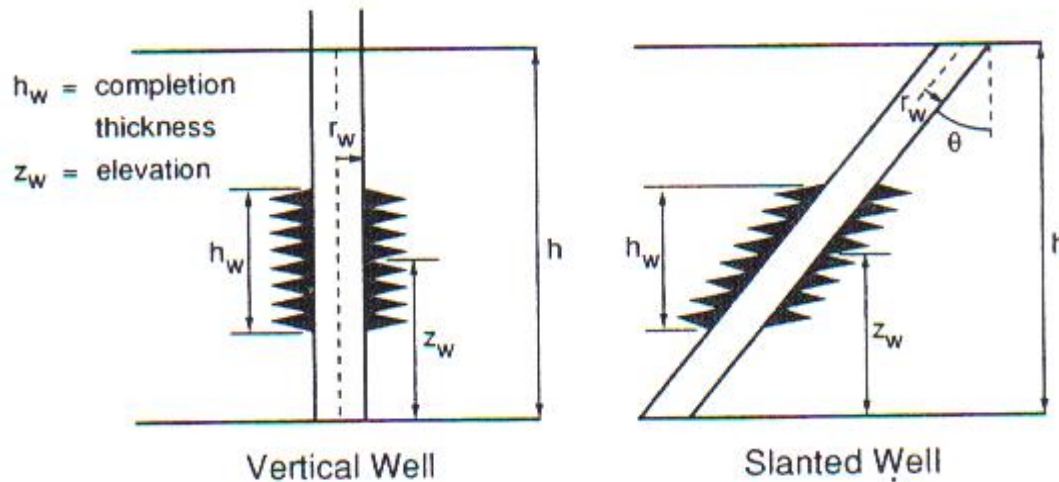

# Skin due to partial completion

- Muskat's Model (1946)

$$s_c = \left\{ \frac{\frac{h}{h_w}}{1 + 7 \sqrt{\frac{r_w}{h_w}} \cos \frac{\pi h_w}{2h}} - 1 \right\} \ln \frac{r_e}{r_w}$$

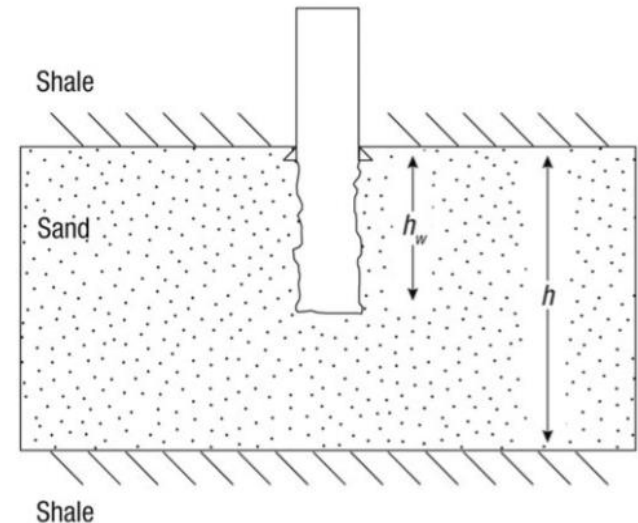

# Skin due to partial completion

Papatzacos Model (1987)

$$h_{wD} = \frac{h_w}{h}$$

$$r_D = \frac{r_w}{h} \sqrt{\frac{k_V}{k_H}}$$

$$h_{1D} = \frac{h_1}{h}$$

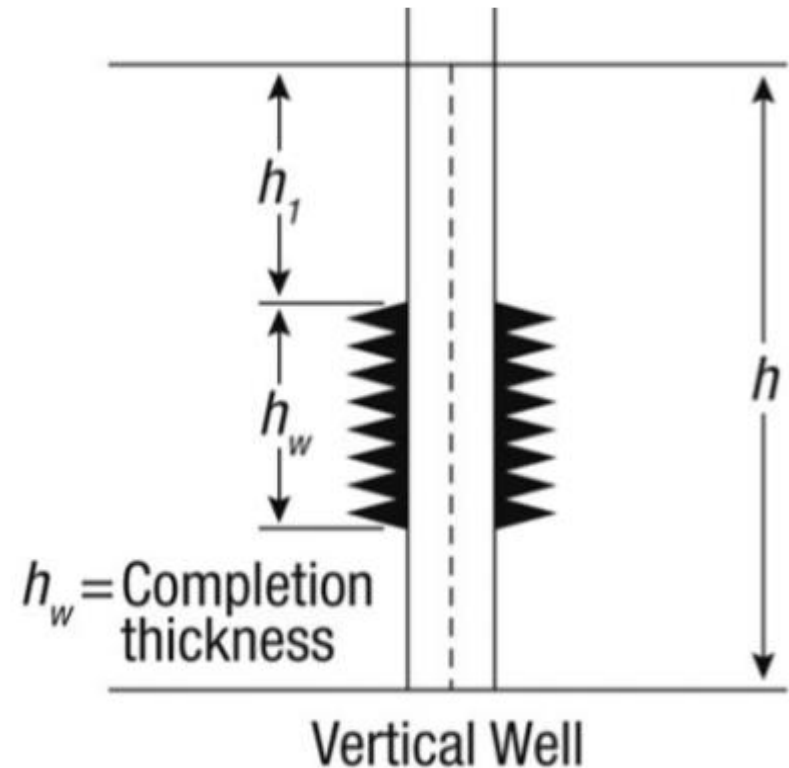

# Skin due to partial completion

Papatzacos Model (1987)

$$S_c = \left( \frac{1}{h_{wD}} - 1 \right) \ln \frac{\pi}{2r_D} + \frac{1}{h_{wD}} \ln \left( \frac{h_{wD}}{2 + h_{wD}} \sqrt{\frac{A-1}{B-1}} \right)$$

$$A = \frac{1}{h_{1D} + \frac{h_{wD}}{4}}$$

$$B = \frac{1}{h_{1D} + \frac{3h_{wD}}{4}}$$

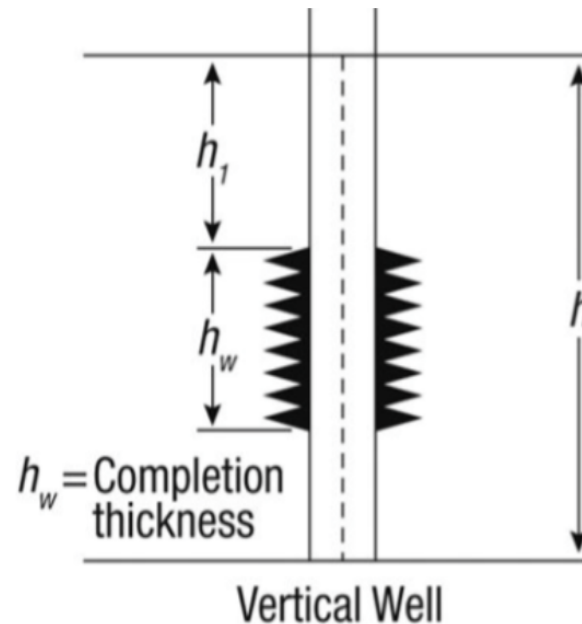

# Skin Factor in Horizontal Well

- Distribution of damage along and normal to a horizontal well. Effect of vertical-to-horizontal Permeability anisotropy

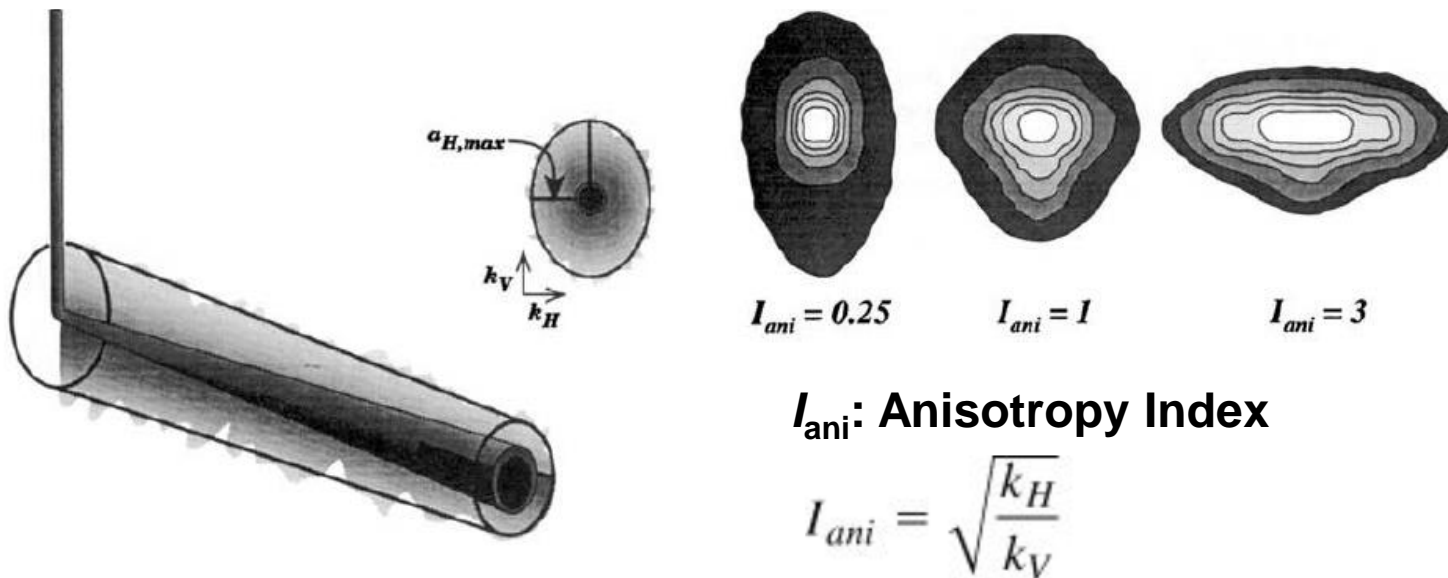

# Heterogeneity Effect on Horizontal Well Skin

- Heterogeneous skin distribution

$a_{H,max}$  the largest horizontal axis (at the heel of the lateral) of the cone of damage

$$s'_{eq} = \left( \frac{k}{k_s} - 1 \right) \ln \left\{ \frac{1}{(I_{ani} + 1)} \sqrt{\frac{4}{3} \left[ \frac{a_{H,max}^2}{r_w^2} + \frac{a_{H,max}}{r_w} + 1 \right]} \right\}$$

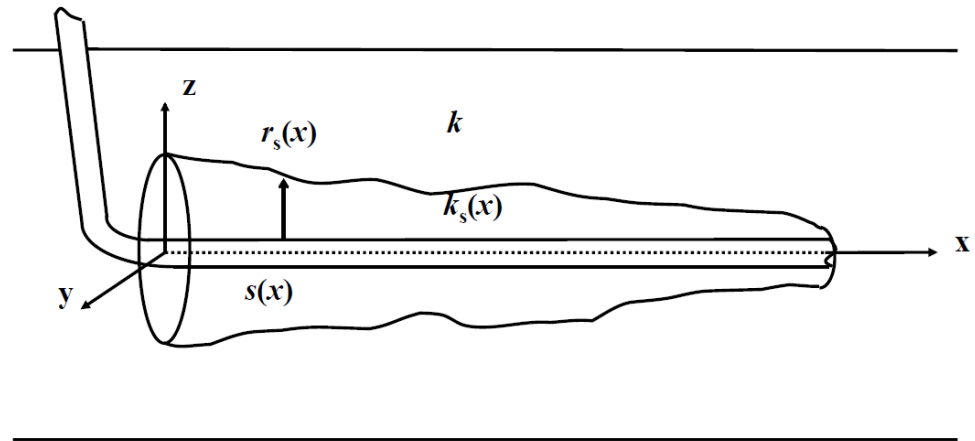

# References

- Prats, M., Hazebroek, P., and Strickler, W.R. 1962. Effect of Vertical Fractures on Reservoir Behavior--Compressible-Fluid Case. SPE J. 2 (2): 87-94. <http://dx.doi.org/10.2118/98-PA>
- Papatzacos, P. 1987. Approximate Partial-Penetration Pseudoskin for Infinite-Conductivity Wells. SPE Res Eng 2 (2): 227–234. SPE-13956-PA. <http://dx.doi.org/10.2118/13956-PA>
- Cinco, H., Miller, F.G., and Ramey, H.J. Jr.: "Unsteady-State Pressure Distribution Created by a Directionally Drilled Well," JPT (November 1975) 1392; Trans., AIME, 259. SPE-5131-PA. <http://dx.doi.org/10.2118/5131-PA>
- Brown, K.E. 1984. The Technology of Artificial Lift Methods, Vol. 4, 134. Tulsa, Oklahoma: PennWell.
- McLeod, H.O.J. 1983. The Effect of Perforating Conditions on Well Performance. Journal of Petroleum Technology 35 (1): 31–39. SPE-10649-PA. <http://dx.doi.org/10.2118/10649-PA>