

Tishk International University
Mechatronics Engineering Department
Microprocessor and Programming
Lecture 1: 8-10-2024



Microprocessor and Programming

Dr. Rand Basil Alhashimie
Email: rand.basil@tiu.edu.iq

Syllabus

1. Computer Organization and Architecture
2. Structure and Function
3. Development of Processors
4. Introduction to Microprocessor
5. Microprocessor Evaluation
6. 8085 Microprocessor
7. 8086 Microprocessor

Assessments Method

Quiz	10%
Homework	5%
Project	10%
Laboratory	10%
Midterm Exam	25%
Final Exam	40%

Outline

- Introduction
- Define the computer
- Brief History of Computers

Computer Organization and Architecture

Computer organization and architecture is the study of the computer internal working. The Architecture of the computer likes a catalog of the available tools for the operating system, while the Organization is the way of how the system is structured, in order to use all these tools.

- **Computer Architecture:** refers to the attributes of a system those visible to the programmer such as:
 - Instruction set, number of bits used to represent data (number, characters), I/O mechanisms, and the technique for addressing memory.

Organization and Architecture

- **Computer Organization:** refers to the operational units and their interconnections, such as: the hardware details those are transparent to the programmer such as control signal, interfaces between the computer and peripherals, and the memory technology used.
- As an example: the architecture issue whether the computer has a multiply instruction. While the organization issue whether the instruction will be implemented by a special multiply unit or by a mechanism that makes repeated use of add unit of the system.
- Historically, and still today, the connection between the architecture and the organization is very important. Many computer manufacturers offer a family of computer models with the same architecture, and differences in the organization. Which leads to have different models in the same family, with different performance and price.

Structure and Function

- A computer is a complex system that contains millions of elementary electronic components. The hierarchical nature of complex systems is essential to both their design and their description. A hierarchical system is a set of interrelated subsystems.
- At a time, the designer needs to deal with a particular level from the hierarchical structure. The behaviors of each level depends on the characteristics of the next lower level. At each level, the designer is concerned with *structure* and *function*.
 - **Structure:** means the way in which the components are interrelated.
 - **Function:** means the operation of each individual components as a part of the structure.

1. Function

The basic functions those can be performed by the computer are:

- Data processing
- Data storage
- Data movement
- Control

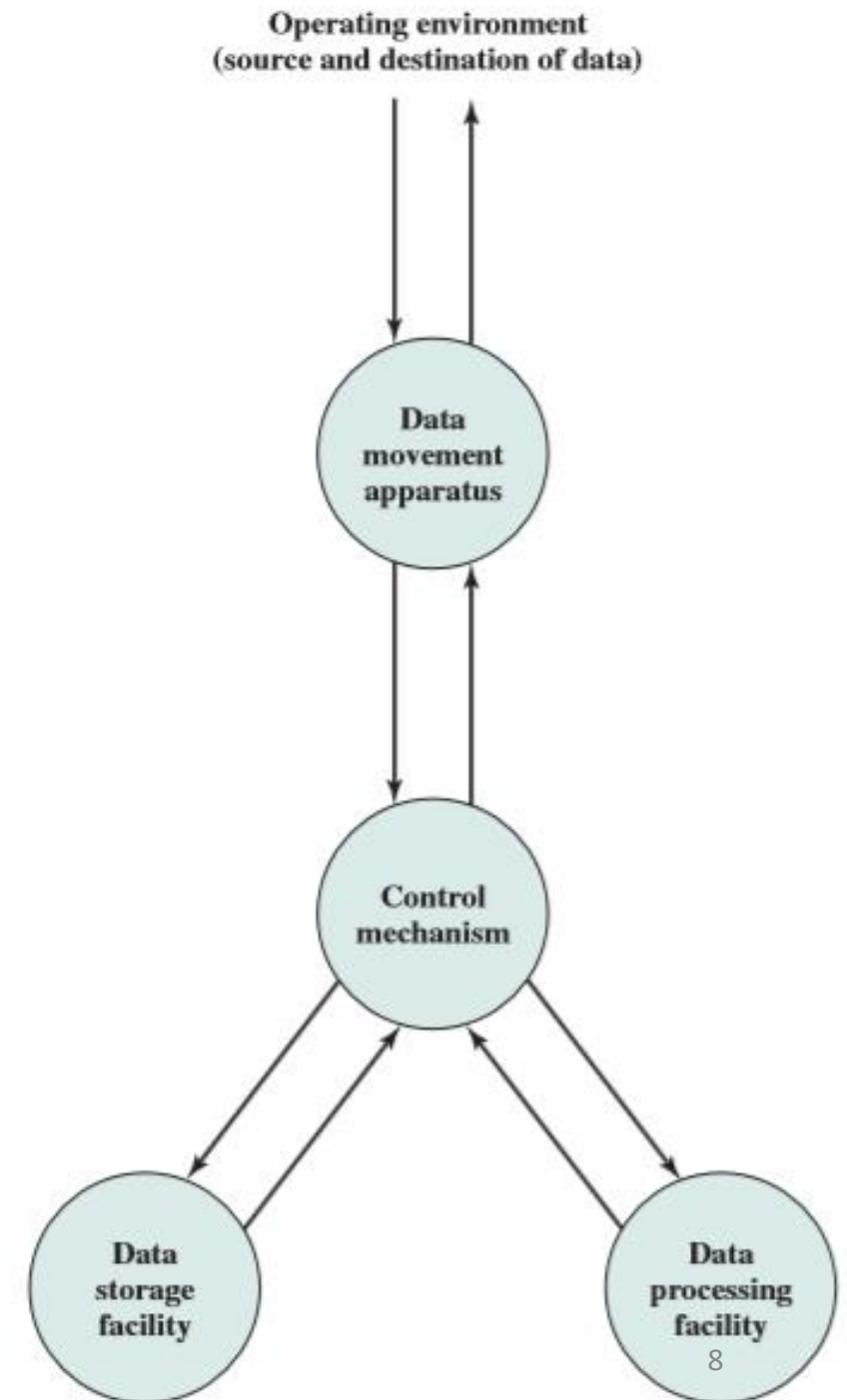

1. Function

- The computer must be able to *process data*. The data may take a wide variety of forms, and the range of processing requirements is broad. However, there are only a few fundamental methods or types of data processing.
- It is also essential that a computer *store data*. Even if the computer is processing data on the fly (i.e., data come in and get processed, and the results go out immediately), the computer must temporarily store at least those pieces of data that are being worked on at any given moment. Thus, there is at least a **short-term data storage** function. Equally important, the computer performs a **long-term data storage** function.
- The computer must be able to *move data* between itself and the outside world. The computer's operating environment consists of devices that serve as either sources or destinations of data.
 - When data are received from or delivered to a device that is directly connected to the computer, the process is known as input–output (I/O), and the device is referred to as a peripheral.
 - When data are moved over longer distances, to or from a remote device, the process is known as data communications.
- Finally, there must be *control* of these three functions. Ultimately, this control is exercised by the individual(s) who provides the computer with instructions. Within the computer, a control unit manages the computer's resources and orchestrates the performance of its functional parts in response to those instructions.

1.1 Data Movement

The number of possible operations that can be performed is few, figure(2) shows four possible types of operations:

1. The computer can function as a data movement device as shown in Fig. (2 a) by simply transferring data from one peripheral or communication line to another.

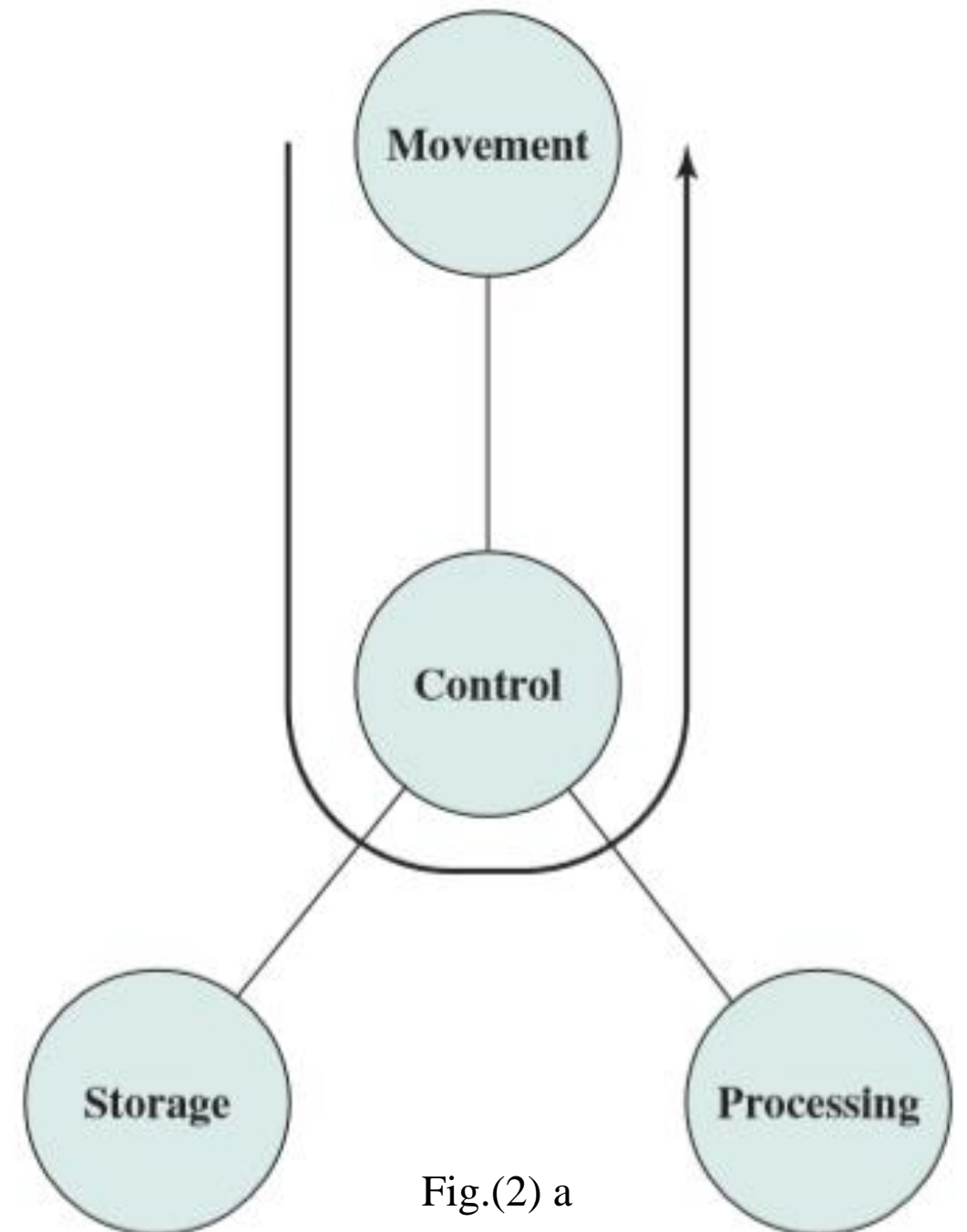

Fig.(2) a

1.2 Data Storage

- 2. It can also function as a data storage device, as shown in Fig.(2 b), with data transferred from the external environment to computer storage (read) and vice versa (write).

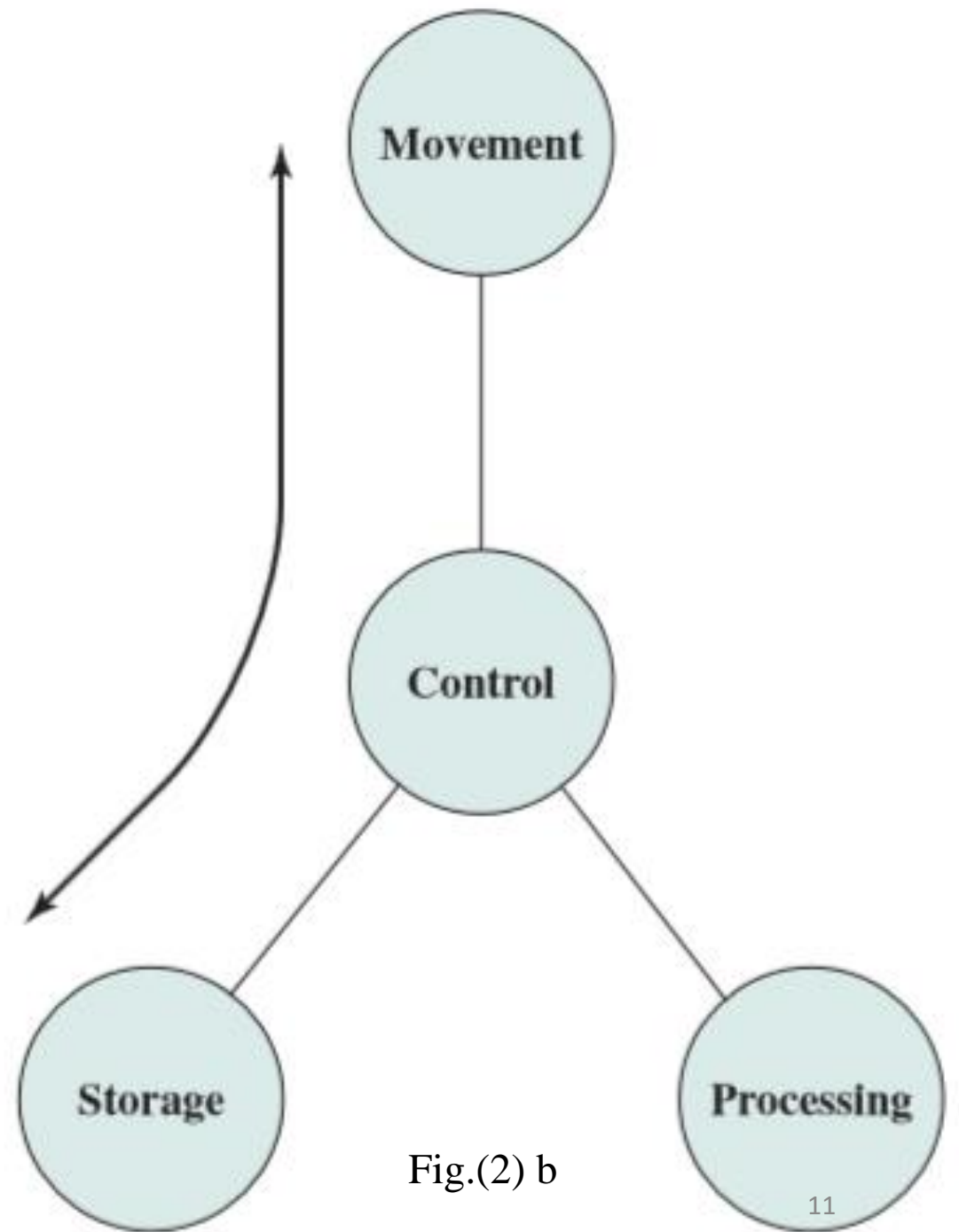

Fig.(2) b

1.3 Data Processing from/to storage

3. Data processing from/to storage as shown in Figure (2c).

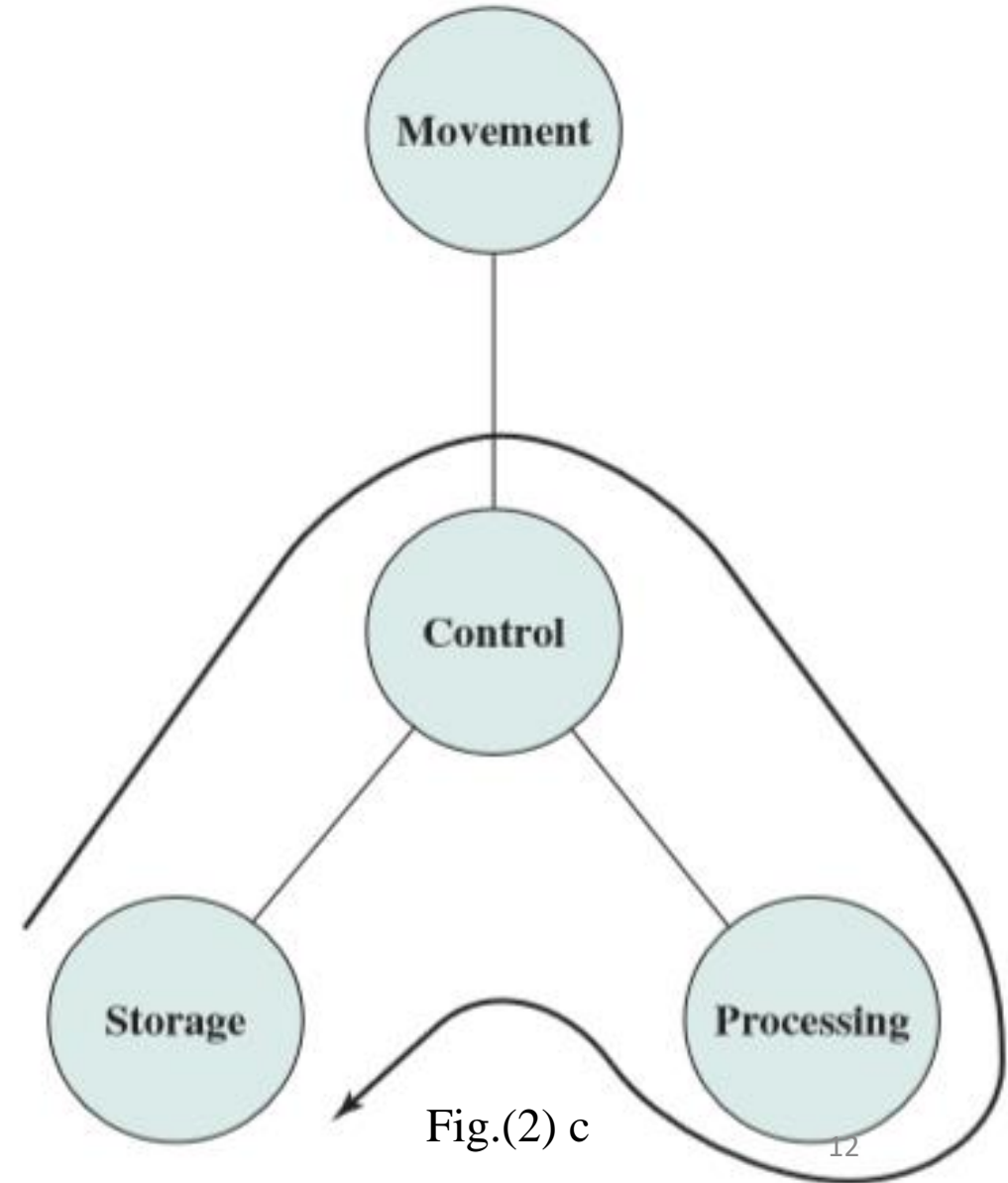
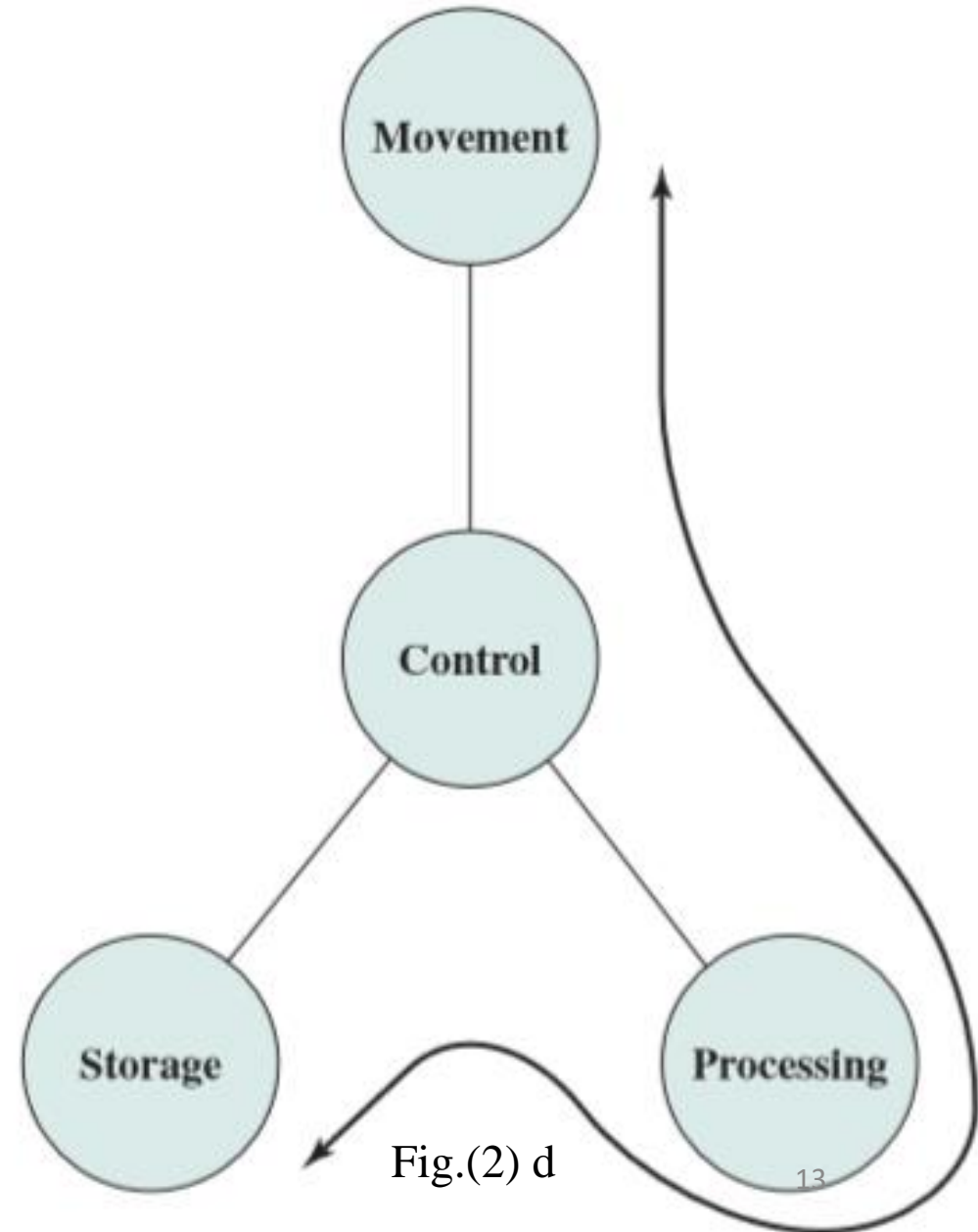

Fig.(2) c

1.4 Data processing to the external environment (I/O)

- 4. Data processing from the storage to the external environment (I/O) as shown in Figure (2d).



2. Structure

Figure 3 is the simplest possible depiction of a computer. The computer interacts in some fashion with its external environment. In general, all of its linkages to the external environment can be classified as peripheral devices or communication lines.

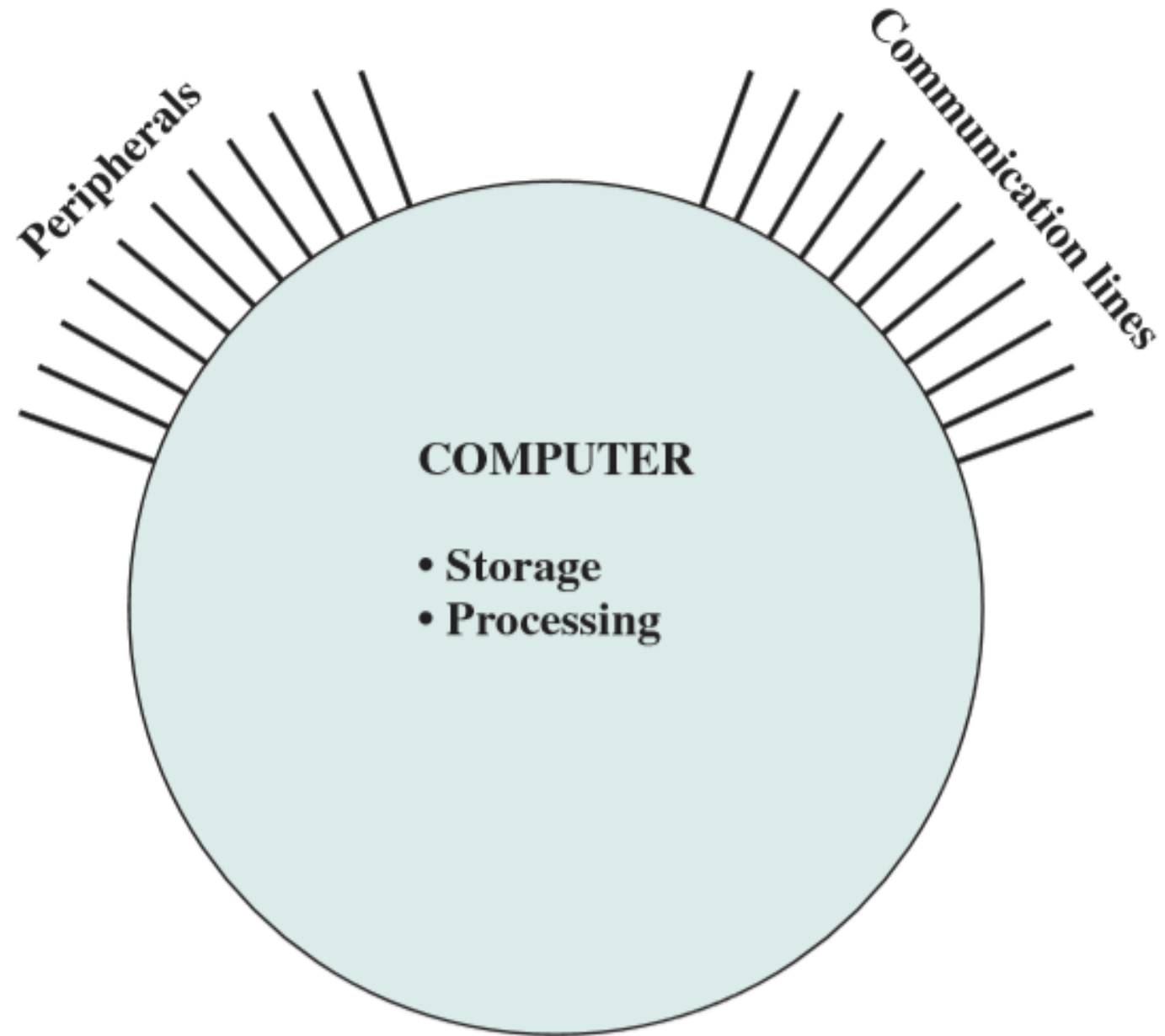

Fig.(3)

2.1 Structure-Top Level

The internal structure of the computer itself, which is shown in Figure (4). There are four main structural components:

- Central processing unit (CPU): Controls the operation of the computer and performs its data processing functions; often simply referred to as processor.
- Main memory: Stores data.
- I/O: Moves data between the computer and its external environment.
- System interconnection: Some mechanism that provides for communication among CPU, main memory, and I/O.

A common example of system interconnection is by means of a system bus, consisting of a number of conducting wires to which all the other components attach.

2.1 Structure-Top Level

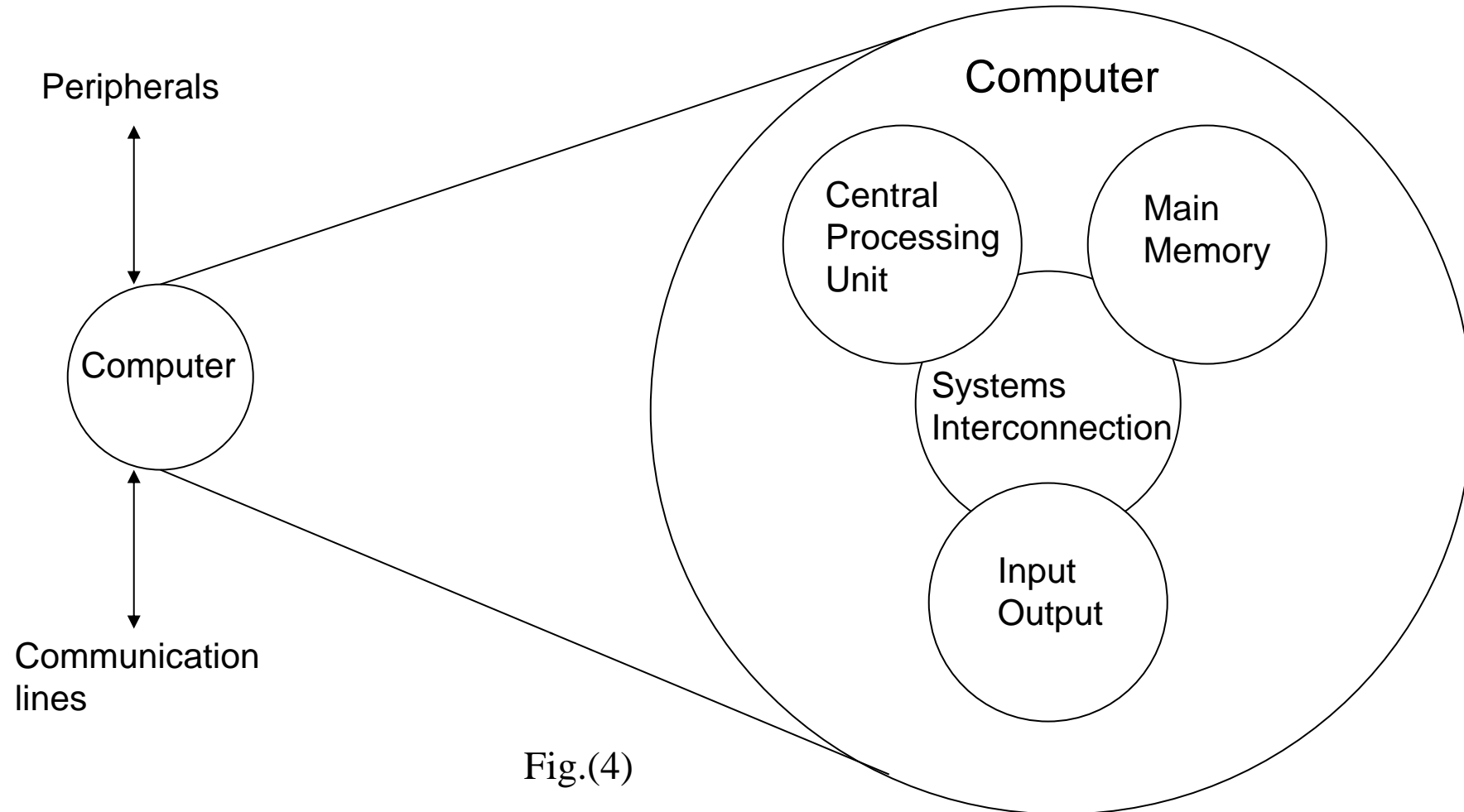

Fig.(4)

2.2 Structure – The CPU

The major structural components in the CPU, as shown in Fig.(5), are as follows:

- Control unit: Controls the operation of the CPU and hence the computer.
- Arithmetic and logic unit (ALU): Performs the computer's data processing functions.
- Registers: Provides storage internal to the CPU.
- CPU interconnection: Some mechanism that provides for communication among the control unit, ALU, and registers.

2.2 Structure – The CPU

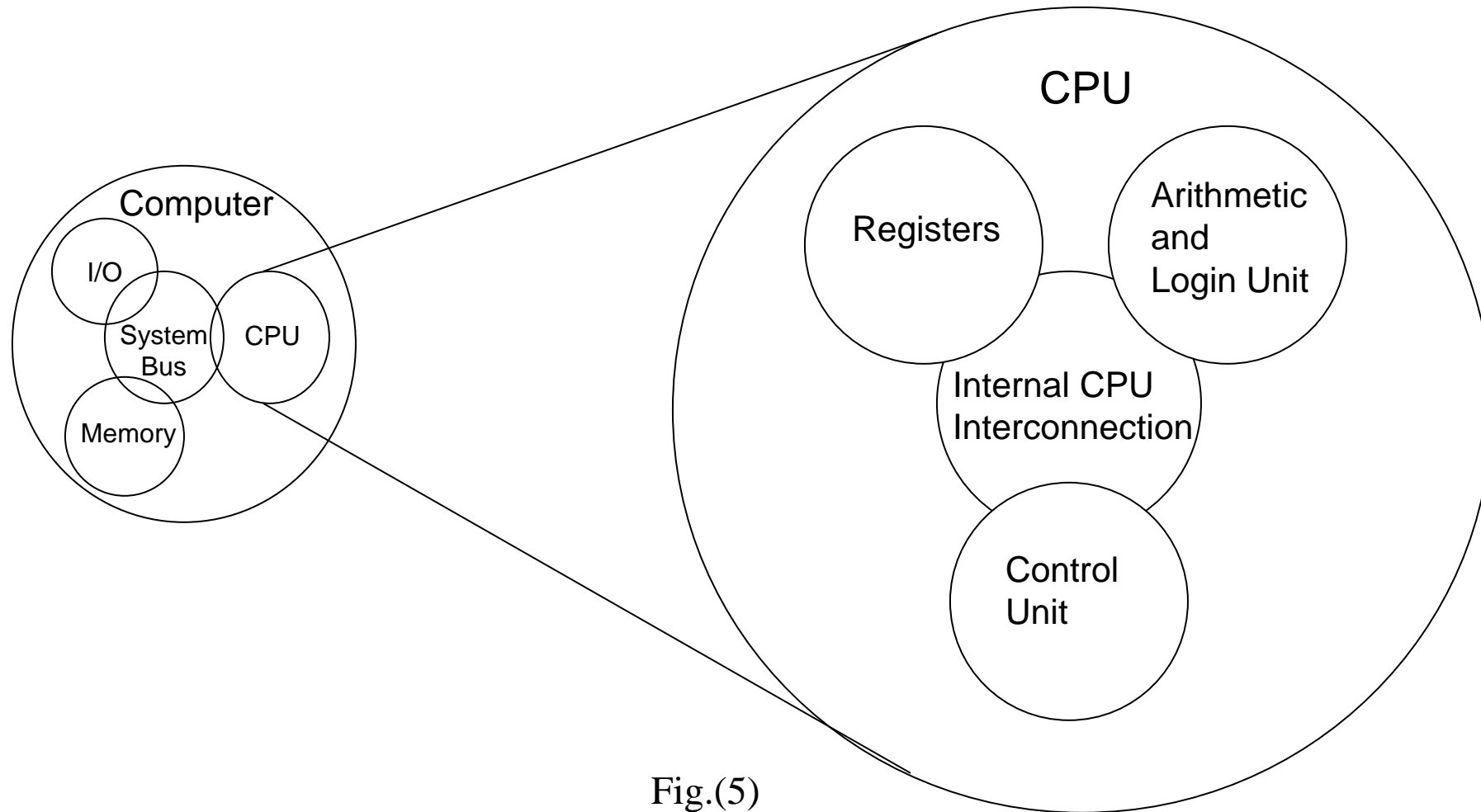

Fig.(5)

2.3 Structure – The Control Unit

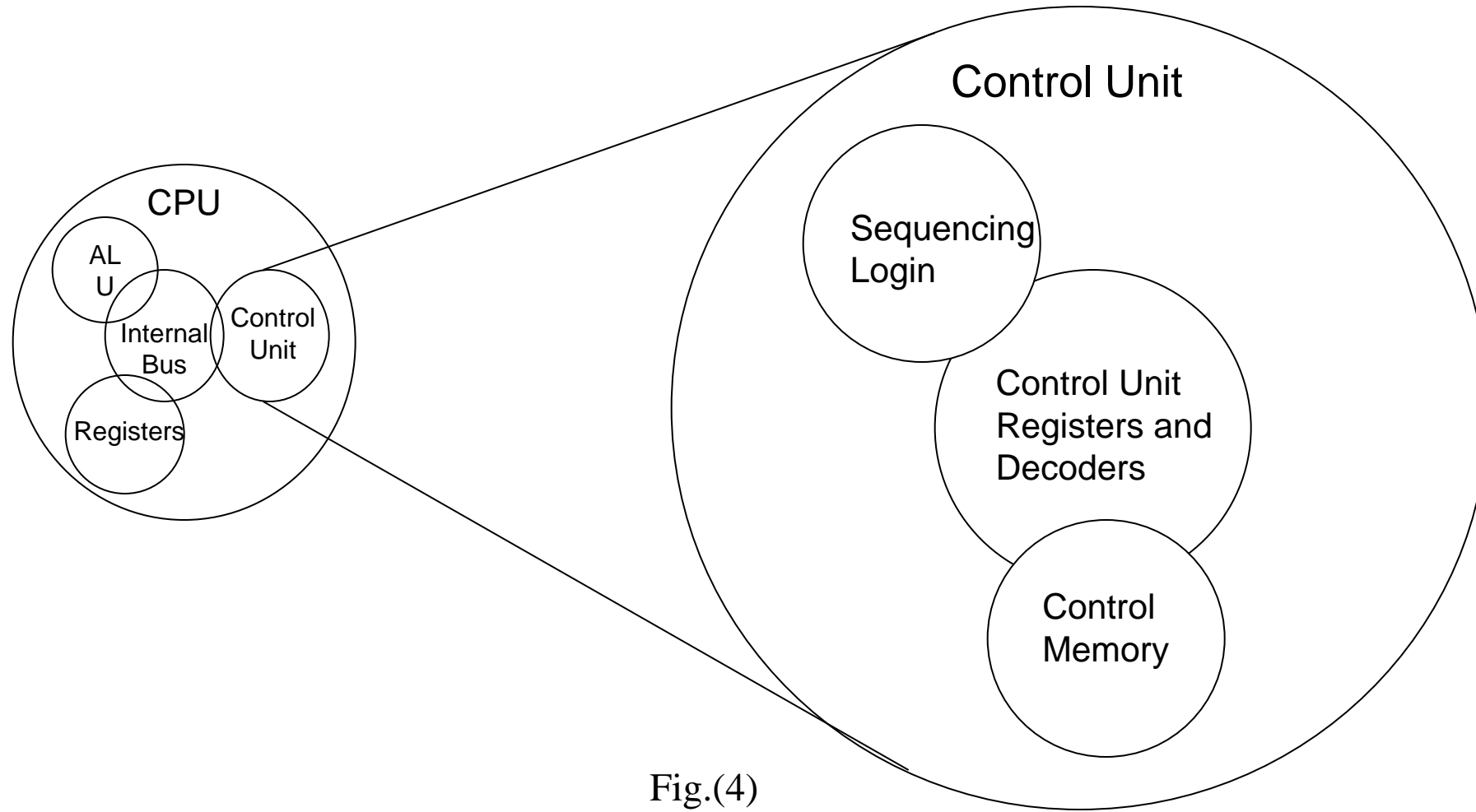

Fig.(4)

Brief History of Computers

- First Generation: Vacuum Tubes
- Second Generation: Transistor
- Third Generation: Integrated Circuit

First Generation: Vacuum Tubes

ENIAC: the ENIAC (Electronic Numerical Integrator And Computer)

- Designed and constructed at the University of Pennsylvania.
- Was the world's first general purpose electronic digital computer.
- The project was a response to U.S. needs during World War II.
- The Army's Ballistics Research Laboratory (BRL), which was responsible for developing range and trajectory tables for new weapons.
- The BRL employed more than 200 people who, using desktop calculators, solved the necessary equations.
- Preparation of the tables for a single weapon would take one person many hours, even days

First Generation: Vacuum Tubes

- John Mauchly, a professor of electrical engineering at the University of Pennsylvania, and John Eckert, one of his graduate students, proposed to build a general-purpose computer using vacuum tubes for the BRL's application.
- In 1943, the Army accepted this proposal, and work began on the ENIAC. The resulting machine was enormous:
 - Weighting 30 tons
 - Occupying 1500 square feet of floor space
 - Containing more than 18,000 vacuum tubes.
 - It consumed 140 kilowatts of power.
 - It was capable of 5000 additions per second
 - Decimal rather than binary

Here you see the nearly 18,000 vacuum tubes and 6,000 switches of the [ENIAC](#), the first electronic computer.

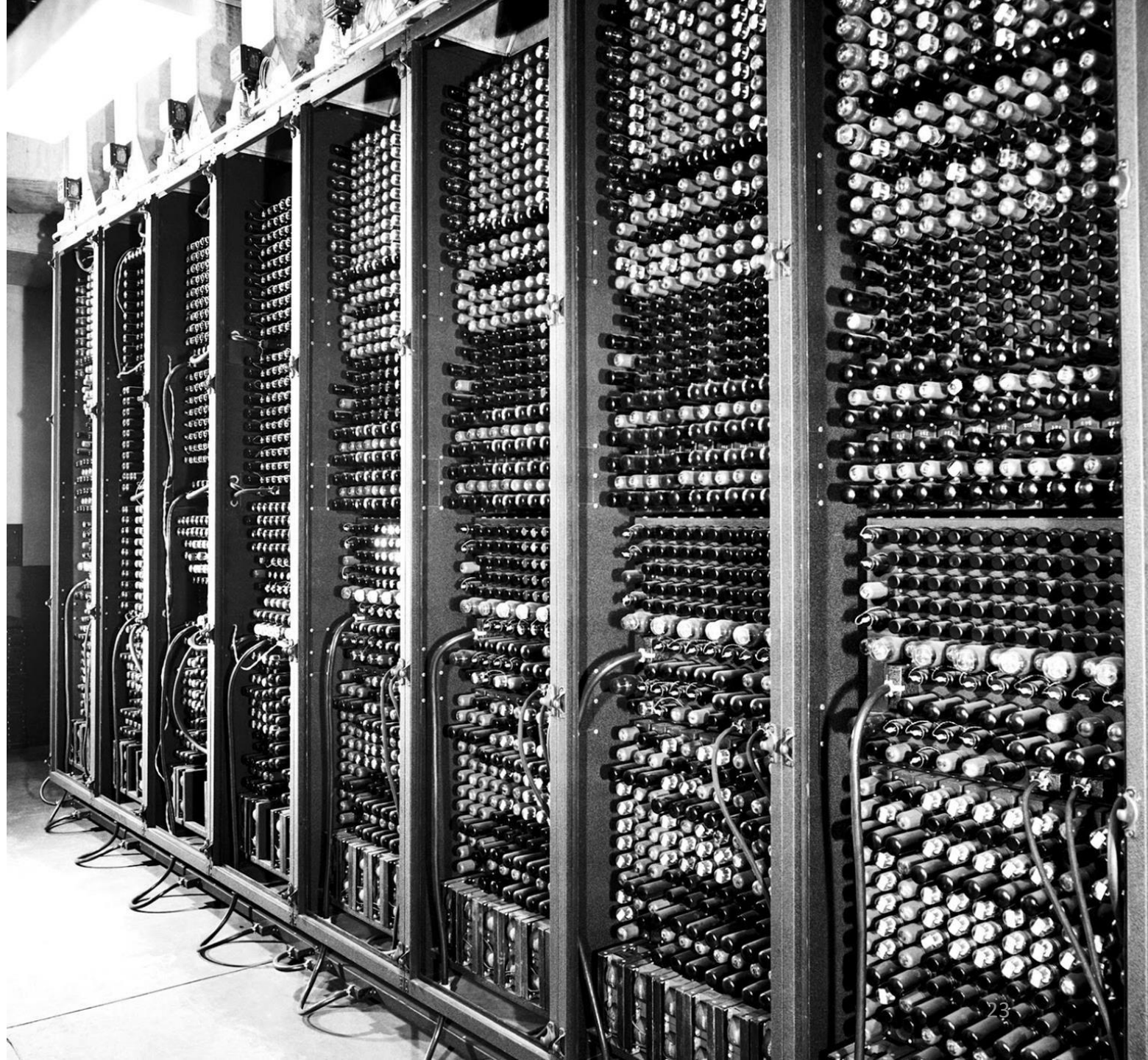

First Generation: Vacuum Tubes

- Its memory consisted of 20 accumulators, each capable of holding a 10-digit decimal number.
- A ring of 10 vacuum tubes represented each digit.
- One vacuum tube was in the ON state, representing one of the 10 digits.
- The major drawback of the ENIAC was that it had to be programmed manually by setting switches and plugging and unplugging cables.
- The ENIAC was completed in 1946.
- The ENIAC continued to operate under BRL management until 1955, when it was disassembled.

First Generation: Vacuum Tubes

- In 1946, von Neumann and his colleagues began the design of a new stored program computer, referred to as the **IAS Computer**, at the New-jersey Institute for Advanced Studies.
- The IAS computer completed in 1952

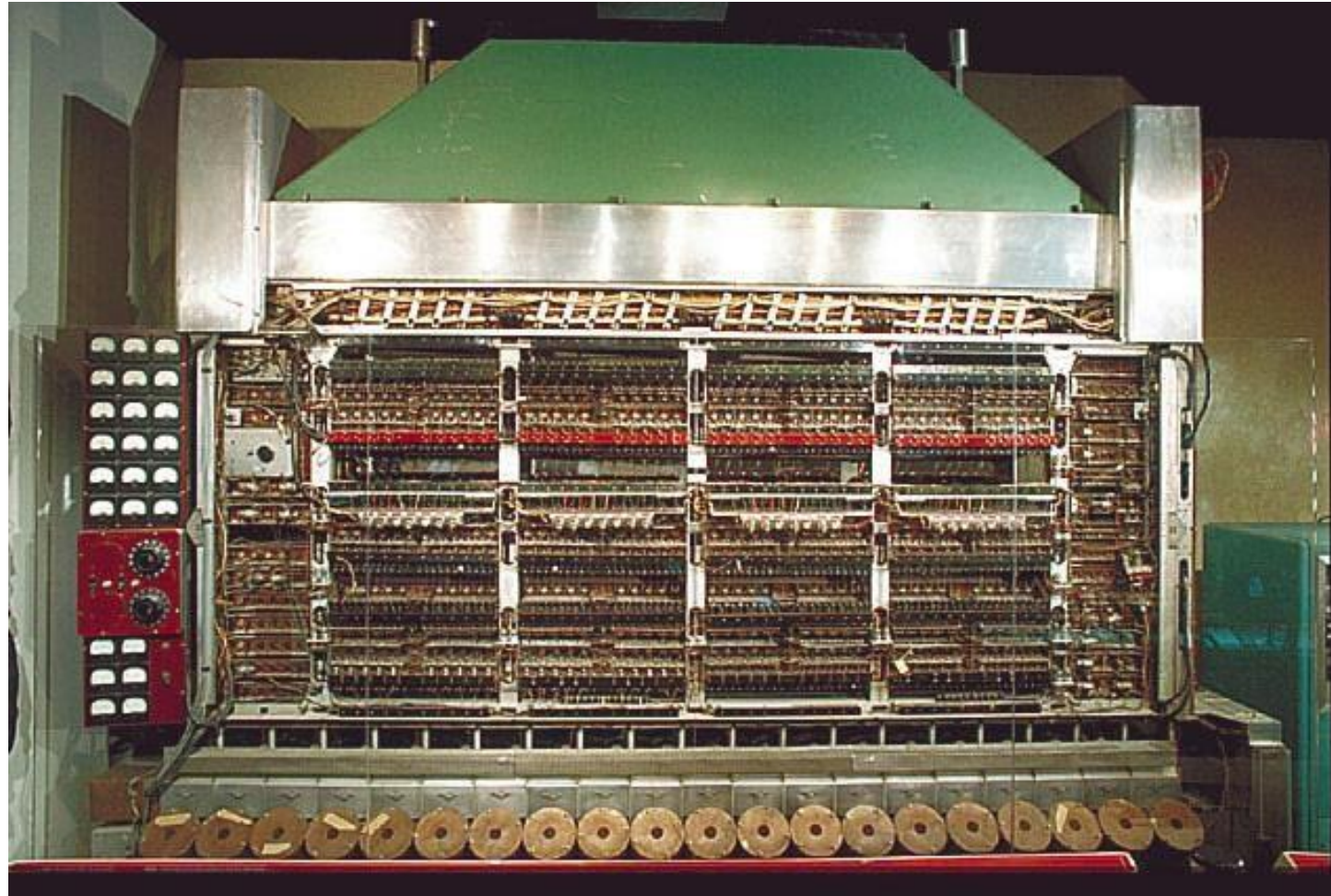

IAS Machine

First Generation: Vacuum Tubes

Figure 1 shows the general structure of the IAS computer. It consists of:

- A main memory , which stores both data and instructions.
- An arithmetic and logic unit (ALU) capable of operating on binary data.
- A control unit, which interprets the instructions in memory and causes them to be executed.
- Input/output (I/O) equipment operated by the control unit.

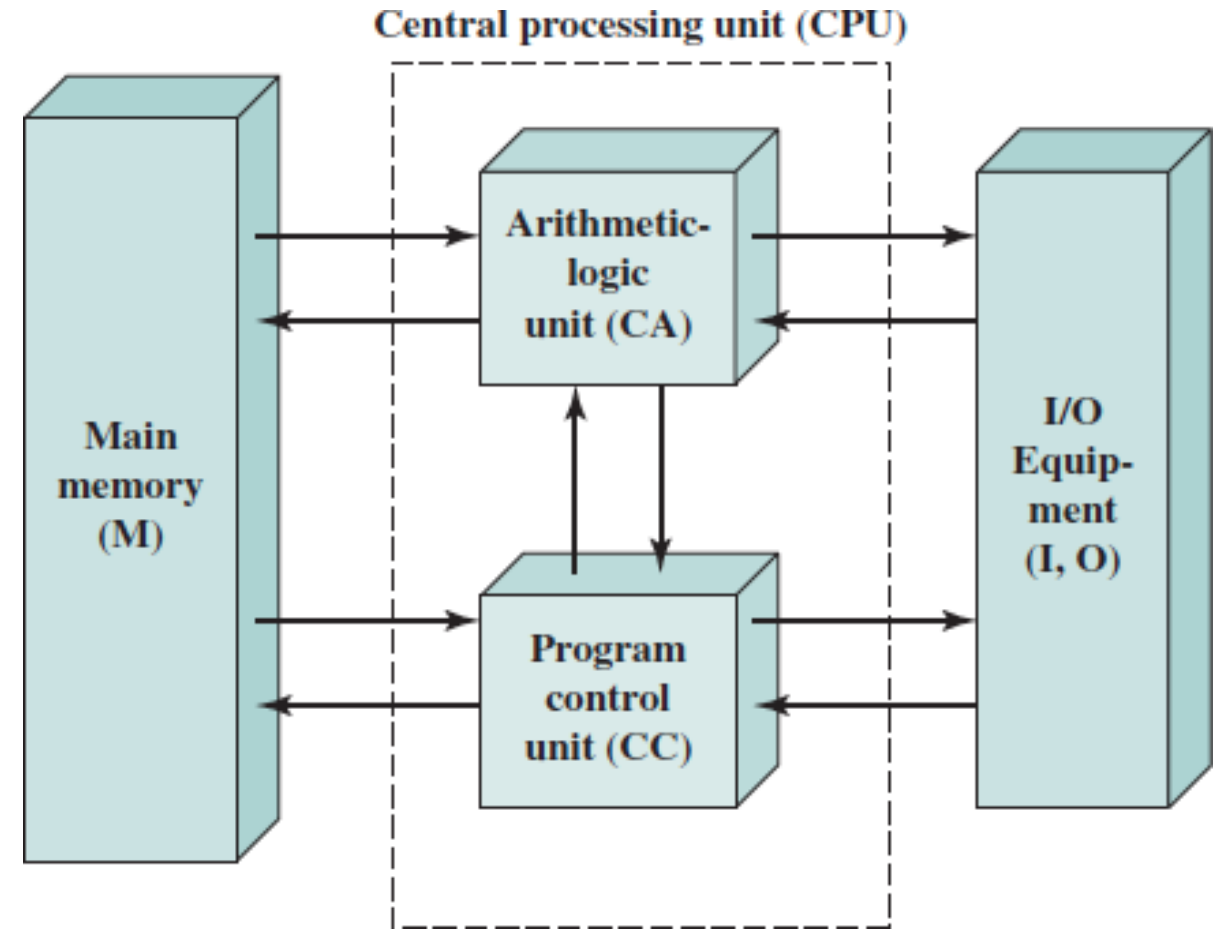

Fig. 1: Structure of the IAS Computer

IAS-details

- Consists 1000 storage locations called word, each has 40 bits.
- Used to store data and instruction
- Numbers represented in binary form
 - 1-bit for sign
 - 39-bits for value
- Instruction is a binary code
 - two 20-bits instructions
 - each consists of 8-bit operation code (opcode)
 - 12-bit address, to specify the word in the memory (0-999)

Structure of IASdetails

Figure 2 reveals that both the control unit and the ALU contain storage locations, called registers , defined as follows:

- **Memory buffer register (MBR):** Contains a word to be stored in memory or sent to the I/O unit or is used to receive a word from memory or from the I/O unit.
- **Memory address register (MAR):** Specifies the address in memory of the word to be written from or read into the MBR.
- **Instruction register (IR):** Contains the 8-bit opcode instruction being executed.

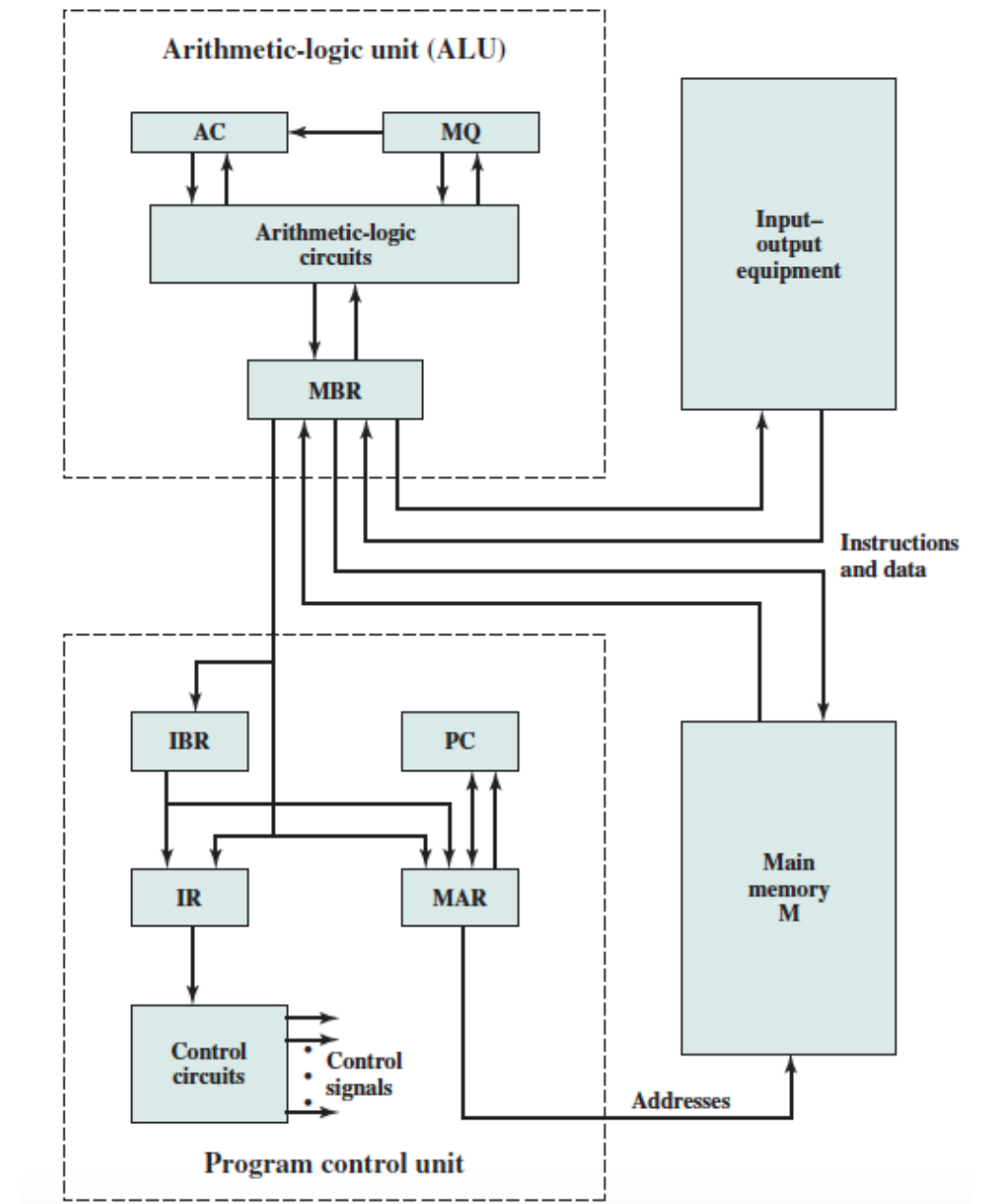
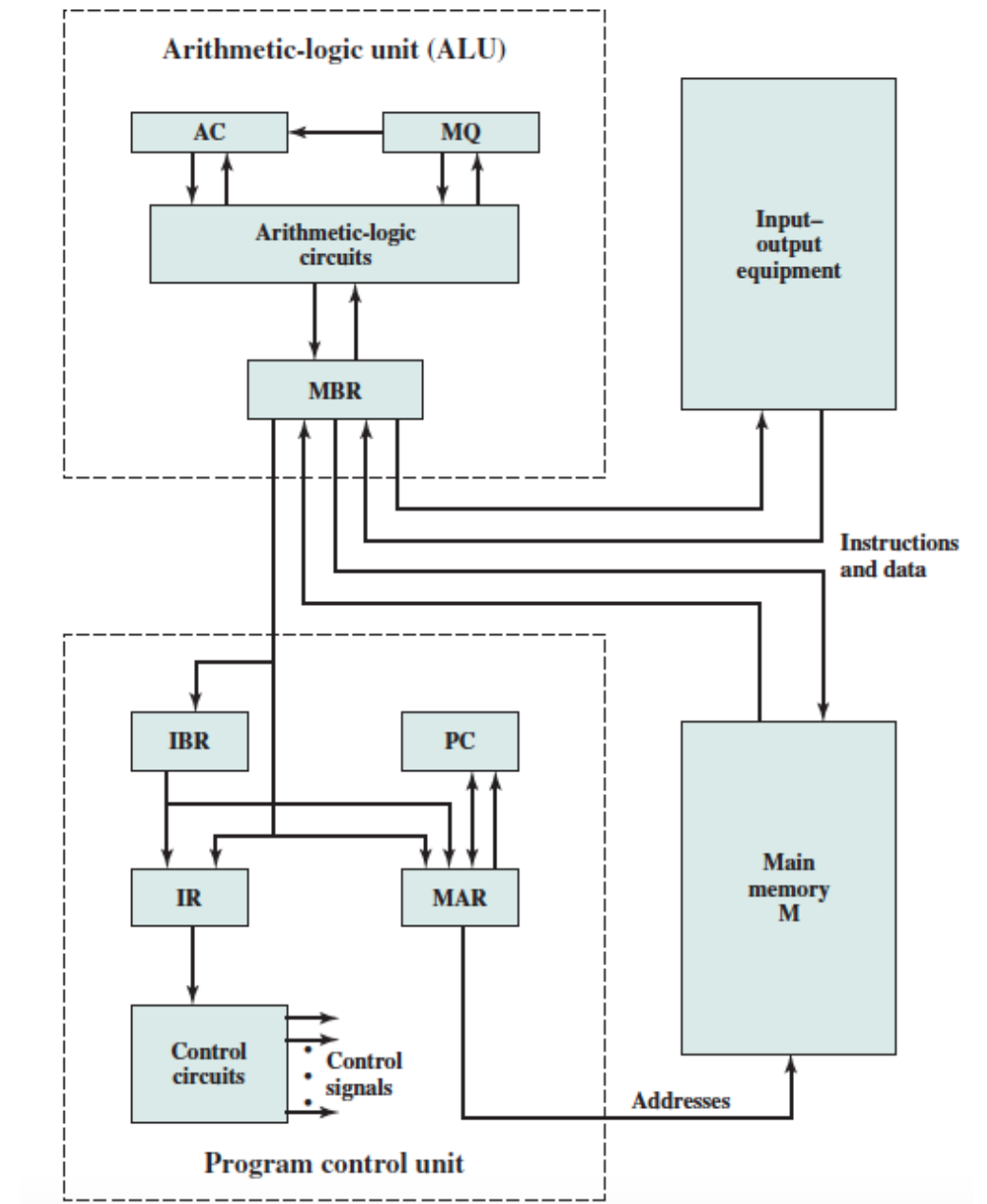

Fig. 2: Expanded Structure of IAS Computer

Structure of IASdetails

- **Instruction buffer register (IBR):** Employed to hold temporarily the right hand instruction from a word in memory.
- **Program counter (PC):** Contains the address of the next instruction pair to be fetched from memory.
- **Accumulator (AC) and multiplier quotient (MQ):** Employed to hold temporarily operands and results of ALU operations. For example, the result of multiplying two 40-bit numbers is an 80-bit number; the most significant 40 bits are stored in the AC and the least significant in the MQ.



Commercial Computers

1. In 1947, Eckert and Mauchly formed the Eckert-Mauchly Computer Corporation to manufacture computers commercially.
 - a. Their first successful machine was the UNIVAC I (Universal Automatic Computer), which was commissioned by the Bureau of the Census for the 1950 calculations.
 - b. The UNIVAC II, which had greater memory capacity and higher performance than the UNIVAC I, was delivered in the late 1950s.

IBM

- Punched-card processing equipment.
- 1953 - the 701
 - IBM's first stored program computer
 - Scientific calculations
- 1955 - the 702
 - Business applications
- Lead to 700/7000 series

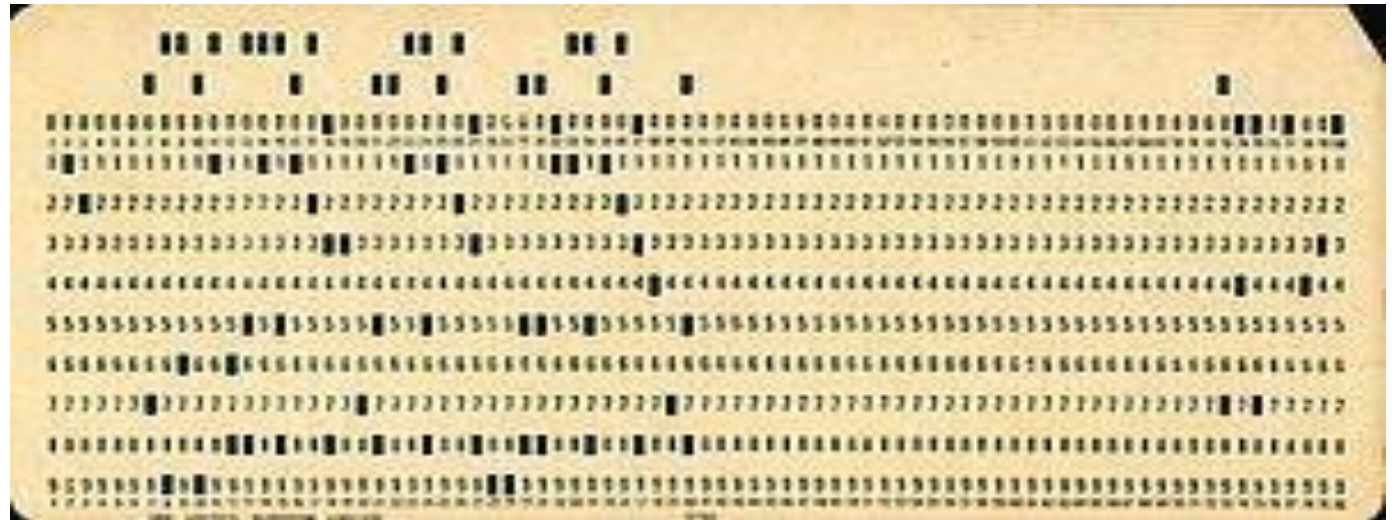
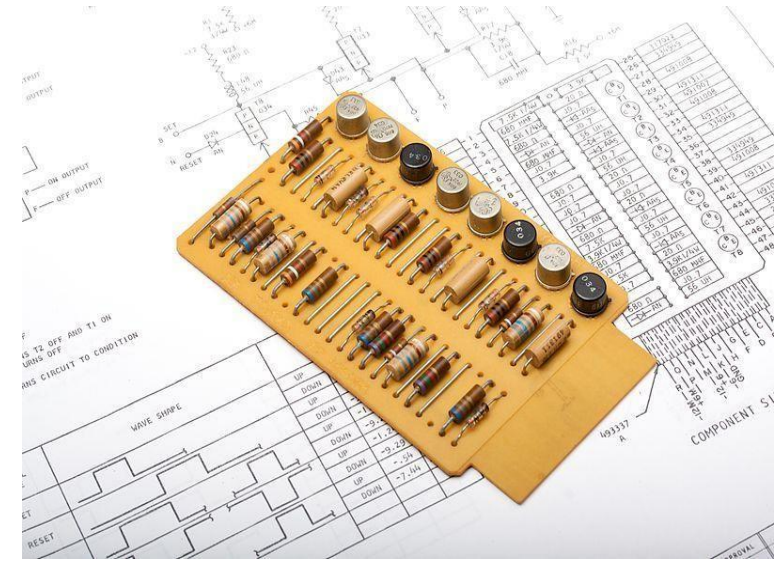

Fig. Punched-card

The Second Generation: Transistor

- Transistor is a replacement of vacuum tube.
- Transistor is:
 - smaller
 - cheaper
 - less heat
 - Made from silicon
- The transistor was invented at Bell Labs in 1947
- By the 1950s had launched an electronic revolution.
- At late 1950s, fully transistorized computers were commercially available.



Transistor based Computers

- The use of the transistor defines the second generation of computers.
- NCR and RCA produced small transistor machines.
- IBM 7000.
- Classify computers into generations based on the fundamental hardware technology employed (Table 1).
- Each new generation is characterized by greater processing performance, larger memory capacity, and smaller size than the previous one.

Table 1: Computer Generations

Generation	Approximate Dates	Technology	Typical Speed (operations per second)
1	1946–1957	Vacuum tube	40,000
2	1958–1964	Transistor	200,000
3	1965–1971	Small- and medium-scale integration	1,000,000
4	1972–1977	Large-scale integration	10,000,000
5	1978–1991	Very-large-scale integration	100,000,000
6	1991–	Ultra-large-scale integration	1,000,000,000

The Third Generation: Integrated Circuits

1. Microelectronics

- Small electronics.
- The basic elements of a digital computer are: **storage, movement, processing, and control functions.**
- Two fundamental types of components are required: **gates and memory cells.**
- A gate is a device that implements a simple Boolean or logical function, such as:

IF A AND B ARE TRUE THEN C IS TRUE (AND gate)

- Such devices are called gates because they control data flow in much the same way that canal gates control the flow of water.
- The memory cell is a device that can store one bit of data; that is, the device can be in one of two stable states at any time.

Microelectronics

- The computer consists of: gates, memory cells, and interconnections.
- The gates and memory cells are constructed of simple digital electronic components.
- The integrated circuit consists components such as transistors, resistors, and conductors can be fabricated from a semiconductor such as silicon.
- Many transistors can be produced at the same time on a single wafer of silicon.

Microelectronics

- Figure 4 reflects the famous Moore's law, which was propounded by Gordon Moore, cofounder of Intel, in 1965.
- Moore observed that the number of transistors that could be put on a single chip was doubling every year and correctly predicted that this pace would continue into the near future.
- To the surprise of many, including Moore, the pace continued year after year and decade after decade. The pace slowed to a doubling every 18 months in the 1970s but has sustained that rate ever since

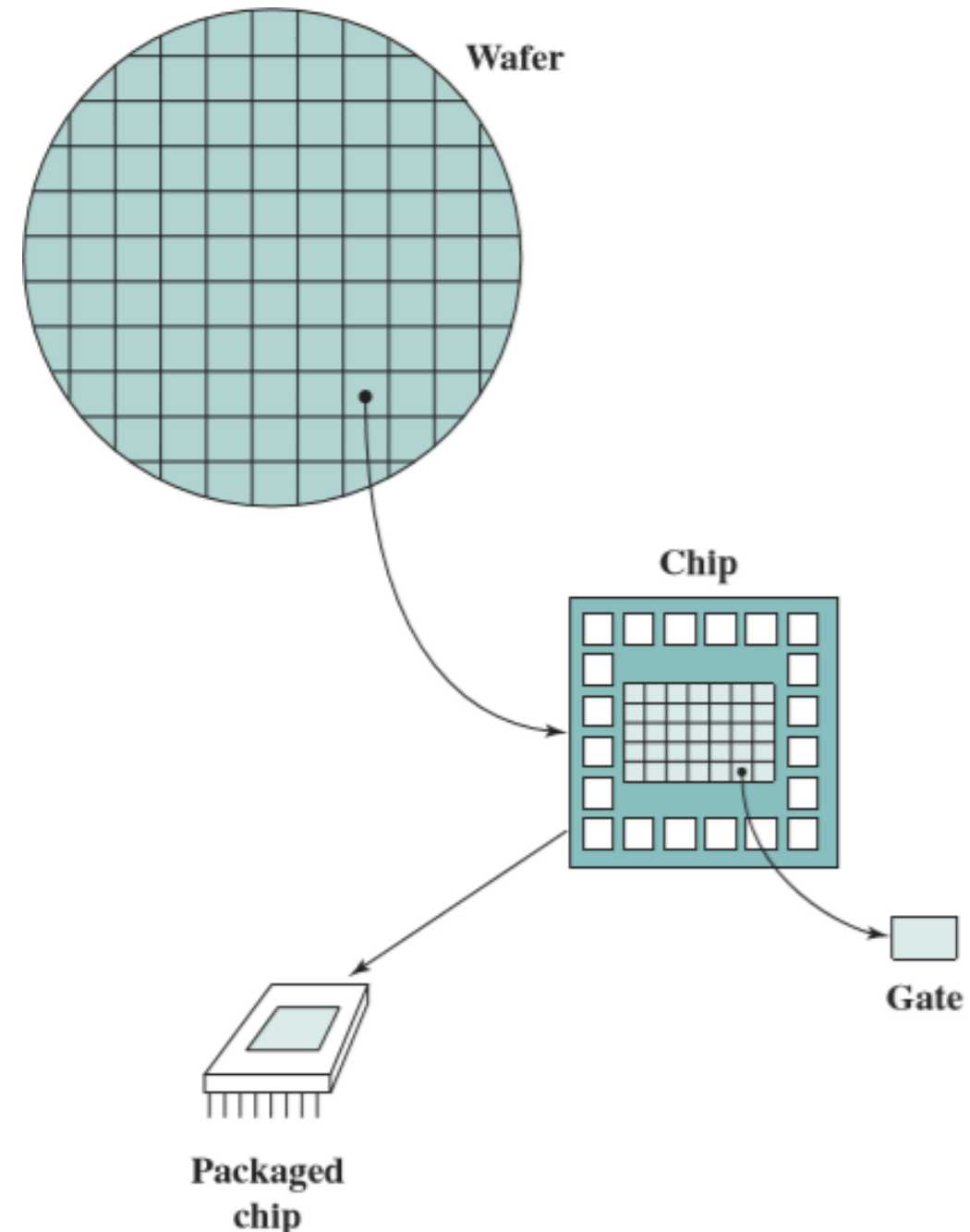
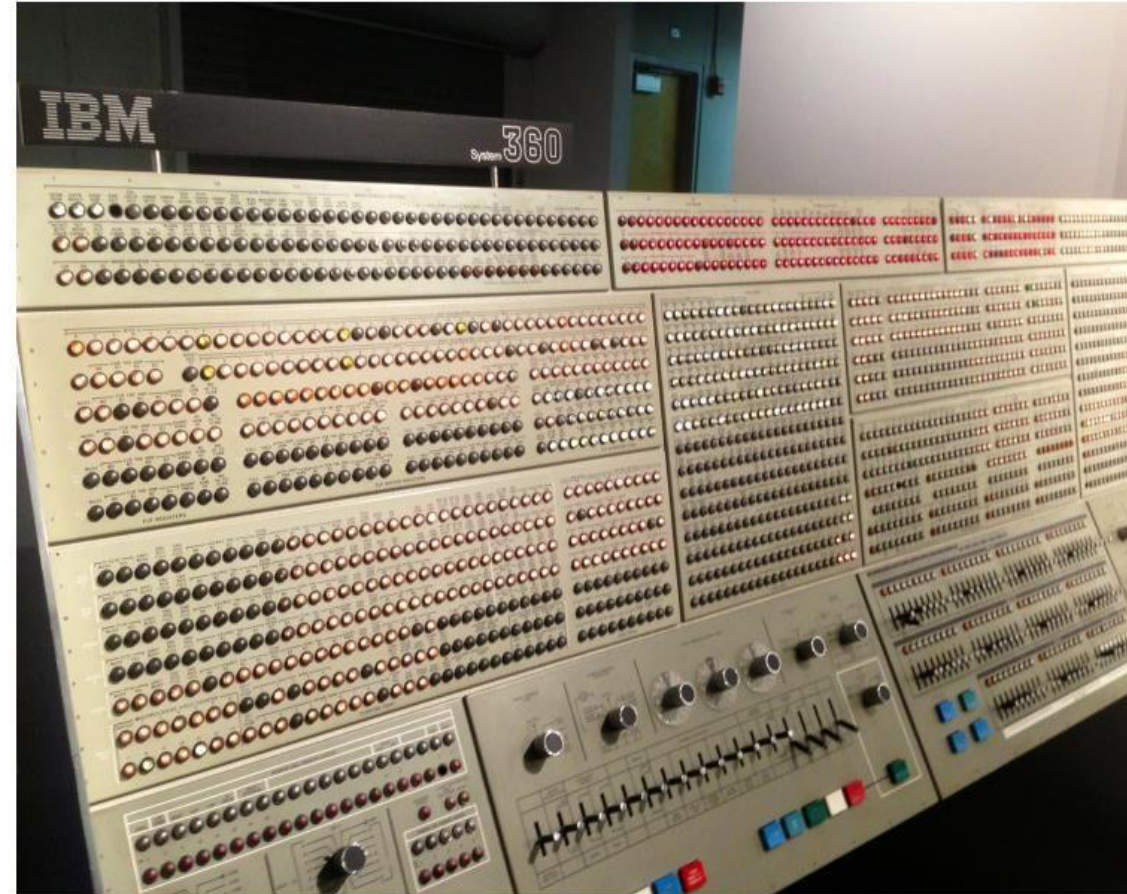

Figure 4: Relation between wafer, chip and gate³⁷

IBM System / 360

- In 1964:
 - IBM is the abbreviation of International Business Machines Corporation
 - IBM announced the System/360, a new family of computer products
 - the 360 product line was incompatible with older IBM machines
 - The System/360 was the industry's first planned family of computers.
 - The family covered a wide range of performance and cost.
 - Following Table indicates some of the key characteristics of the various models in 1965 (each member of the family is distinguished by a model number).
 - The models were compatible in the sense that a program written for one model should be capable of being executed by another model in the series, with only a difference in the time it takes to execute.



IBM System / 360

Characteristic	Model 30	Model 40	Model 50	Model 65	Model 75
Maximum memory size (bytes)	64K	256K	256K	512K	512K
Data rate from memory (Mbytes/s)	0.5	0.8	2.0	8.0	16.0
Processor cycle time (μ s)	1.0	0.625	0.5	0.25	0.2
Relative speed	1	3.5	10	21	50
Maximum number of data channels	3	3	4	6	6
Maximum data rate on one channel (Kbytes/s)	250	400	800	1250	1250

The characteristics of System/360 family are as follows:

- **Similar or identical instruction set:** In many cases, the exact same set of machine instructions is supported on all members of the family. Thus, a program that executes on one machine will also execute on any other. In some cases, the lower end of the family has an instruction set that is a subset of that of the top end of the family. This means that programs can move up but not down.
- **Similar or identical operating system:** The same basic operating system is available for all family members. In some cases, additional features are added to the higher-end members.
- **Increasing speed:** The rate of instruction execution increases in going from lower to higher family members.
- **Increasing number of I/O ports:** The number of I/O ports increases in going from lower to higher family members.
- **Increasing memory size:** The size of main memory increases in going from lower to higher family members.
- **Increasing cost:** At a given point in time, the cost of a system increases in going from lower to higher family members.

How could such a family concept be implemented?

Differences were achieved based on three factors: *basic speed, size, and degree of simultaneity*. For example, greater speed in the execution of a given instruction could be gained by the use of more complex circuitry in the ALU, allowing sub operations to be carried out in parallel.

Another way of increasing speed was to increase the width of the data path between main memory and the CPU. On the Model 30, only 1 byte (8 bits) could be fetched from main memory at a time, whereas 8 bytes could be fetched at a time on the Model 75. The System/360 not only dictated the future course of IBM but also had a profound impact on the entire industry. Many of its features have become standard on other large computers.

DEC PDP-8

DEC PDP : is a 12-bit minicomputer produced by Digital Equipment Corporation in 1964

- First minicomputer (after miniskirt!)
- Did not need air conditioned room
- Small enough to sit on a lab bench
- \$16,000
 - \$100k+ for IBM 360
- Embedded applications & OEM
- BUS STRUCTURE

DEC PDP-8

PDP-8 bus, called the Omnibus, consists of 96 separate signal paths, used to carry control, address, and data signals. Because all system components share a common set of signal paths, their use can be controlled by the CPU.

This architecture is highly flexible, allowing modules to be plugged into the bus to create various configurations.

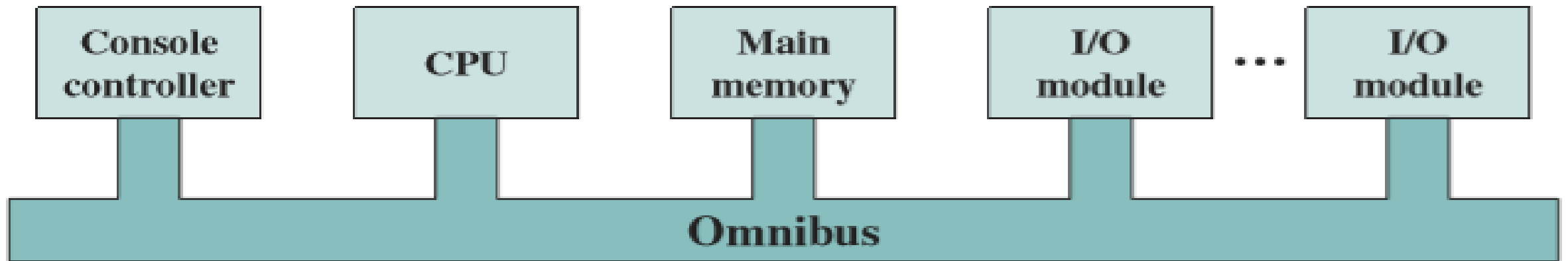

Fig. 6: PDP-8 Bus Structure

DEC PDP-8

Table 3: Evaluation of PDP-8

Model	First Shipped	Cost of Processor + 4K 12-bit Words of Memory (\$1000s)	Data Rate from Memory (words/μs)	Volume (cubic feet)	Innovations and Improvements
PDP-8	4/65	16.2	1.26	8.0	Automatic wire-wrapping production
PDP-8/5	9/66	8.79	0.08	3.2	Serial instruction implementation
PDP-8/1	4/68	11.6	1.34	8.0	Medium-scale integrated circuits
PDP-8/L	11/68	7.0	1.26	2.0	Smaller cabinet
PDP-8/E	3/71	4.99	1.52	2.2	Omnibus
PDP-8/M	6/72	3.69	1.52	1.8	Half-size cabinet with fewer slots than 8/E
PDP-8/A	1/75	2.6	1.34	1.2	Semiconductor memory; floating-point processor

Semiconductor Memory

The first application of integrated circuit technology to computers was construction of the processor (the control unit and the arithmetic and logic unit) out of integrated circuit chips. But it was also found that this same technology could be used to construct memories.

- In 1970
- Fairchild
- Size of a single core
 - i.e. 1 bit of magnetic core storage
- Holds 256 bits
- Non-destructive read
- Much faster than core
- Capacity approximately doubles each year

Semiconductor Memory

In 1974, a seminal event occurred:

- The price per bit of semiconductor memory dropped below the price per bit of core memory.
- Rapid decline in memory cost
- Increase in physical memory density.
- Led to smaller, faster machines with memory sizes of larger and more expensive machines from just a few years earlier.
- The computer has been used with office machines and personal computers.

Since 1970, semiconductor memory has been through 13 generations:

- 1K, 4K, 16K, 64K, 256K, 1M, 4M, 16M, 64M, 256M, 1G, 4G, and, as of this writing, 16Gbits
- on a single chip ($1K = 2^{10}$, $1M = 2^{20}$, $1G = 2^{30}$).
- Each generation has provided four times the storage density of the previous generation, accompanied by declining cost per bit and declining access time.

Microprocessor – Part 1

- As time went on, more and more elements were placed on each chip, so that fewer and fewer chips were needed to construct a single computer processor.
- A breakthrough was achieved in **1971**, when Intel developed its **4004**.
 - The 4004 was the first chip to contain all of the components of a CPU on a single chip: The microprocessor was born.
 - The 4004 can add two 4-bit numbers and can multiply only by repeated addition. By today's standards, the 4004 is hopelessly primitive, but it marked the beginning of a continuing evolution of microprocessor capability and power.
- This evolution can be seen most easily in the number of bits that the processor deals with at a time.
- The best measure is the ***data bus width***: the number of bits of data that can be brought into or sent out of the processor at a time.
- Another measure is ***the number of bits in the accumulator or in the set of general-purpose registers***. Often, these measures coincide, but not always. For example, a number of microprocessors were developed that operate on 16-bit numbers in registers but can only read and write 8 bits at a time.
- In **1972 - Intel 8008**, which was the first 8-bit microprocessor and was almost twice as complex as the 4004.

(a) 1970s Processors

	4004	8008	8080	8086	8088
Introduced	1971	1972	1974	1978	1979
Clock speeds	108 kHz	108 kHz	2 MHz	5 MHz, 8 MHz, 10 MHz	5 MHz, 8 MHz
Bus width	4 bits	8 bits	8 bits	16 bits	8 bits
Number of transistors	2300	3500	6000	29,000	29,000
Feature size (μm)	10		6	3	6
Addressable memory	640 Bytes	16 kB	64 kB	1 MB	1 MB

(b) 1980s Processors

	80286	386TM DX	386TM SX	486TM DX CPU
Introduced	1982	1985	1988	1989
Clock speeds	6 MHz–12.5 MHz	16 MHz–33 MHz	16 MHz–33 MHz	25 MHz–50 MHz
Bus width	16 bits	32 bits	16 bits	32 bits
Number of transistors	134,000	275,000	275,000	1.2 million
Feature size (μm)	1.5	1	1	0.8–1
Addressable memory	16 MB	4 GB	16 MB	4 GB
Virtual memory	1 GB	64 TB	64 TB	64 TB
Cache	—	—	—	8 kB

Microprocessor Evaluation – Part 2

- In **1974** - **Intel 8080**, which was the first general-purpose microprocessor. Whereas the 4004 and the 8008 had been designed for specific applications, the 8080 was designed to be the CPU of a general-purpose microcomputer.
- Like the 8008, the 8080 is an 8-bit microprocessor. The 8080, however, is faster, has a richer instruction set, and has a large addressing capability.
- About the same time, 16-bit microprocessors began to be developed. However, it was not until the end of the 1970s that powerful, general-purpose 16-bit microprocessors appeared. One of these was the 8086.
- The next step in this trend occurred in 1981, when both Bell Labs and Hewlett-Packard developed 32-bit, single-chip microprocessors.
- Intel introduced its own 32-bit microprocessor, the 80386, in 1985.

(c) 1990s Processors

	486TM SX	Pentium	Pentium Pro	Pentium II
Introduced	1991	1993	1995	1997
Clock speeds	16 MHz–33 MHz	60 MHz–166 MHz,	150 MHz–200 MHz	200 MHz–300 MHz
Bus width	32 bits	32 bits	64 bits	64 bits
Number of transistors	1.185 million	3.1 million	5.5 million	7.5 million
Feature size (μm)	1	0.8	0.6	0.35
Addressable memory	4 GB	4 GB	64 GB	64 GB
Virtual memory	64 TB	64 TB	64 TB	64 TB
Cache	8 kB	8 kB	512 kB L1 and 1 MB L2	512 kB L2

(d) Recent Processors

	Pentium III	Pentium 4	Core 2 Duo	Core i7 EE 990
Introduced	1999	2000	2006	2011
Clock speeds	450–660 MHz	1.3–1.8 GHz	1.06–1.2 GHz	3.5 GHz
Bus width	64 bits	64 bits	64 bits	64 bits
Number of transistors	9.5 million	42 million	167 million	1170 million
Feature size (nm)	250	180	65	32
Addressable memory	64 GB	64 GB	64 GB	64 GB
Virtual memory	64 TB	64 TB	64 TB	64 TB
Cache	512 kB L2	256 kB L2	2 MB L2	1.5 MB L2/12 MB L3

Designing for Performance

Year by year, the cost of computer systems continues to drop dramatically, while the performance and capacity of those systems continue to rise equally dramatically. Today's laptops have the computing power of an IBM mainframe from 10 or 15 years ago. Thus, we have virtually "free" computer power. Processors are so inexpensive that we now have microprocessors we throw away. The digital pregnancy test as an example (used once and then thrown away). And this continuing technological revolution has enabled the development of applications of astounding complexity and power. For example, desktop applications that require the great power of today's microprocessor-based systems include:

- Image processing
- Speech recognition
- Videoconferencing
- Multimedia authoring
- Voice and video annotation of files
- Simulation modeling

Microprocessor Performance

- **Processor Speed Increased:** The relentless pursuit of speed by processor chip manufacturers that gives Intel x86 processors or IBM mainframe computers “mind-boggling power”. The evolution of these machines based on “Moore’s law”.
 - Chipmakers can unleash a new generation of chips every three years.
- **Memory capacity increased:** In memory chips, every three years, the **capacity** of dynamic random-access memory (DRAM) is quadrupled (x4), when the DRAM is the basic technology for computer main memory.
- In microprocessors, the addition of new circuits, and the speed increased by reducing the distances between them, has improved performance four- or five fold every three years or so since Intel launched its x86 family in 1978.

Techniques built into Contemporary Processors

1. Pipelining:

- a. Processor can simultaneously work on multiple instructions.
- b. The processor overlaps operations by moving data or instructions into a conceptual pipe with all stages of the pipe processing simultaneously.

For example, while one instruction is being executed, the computer is decoding the next instruction.

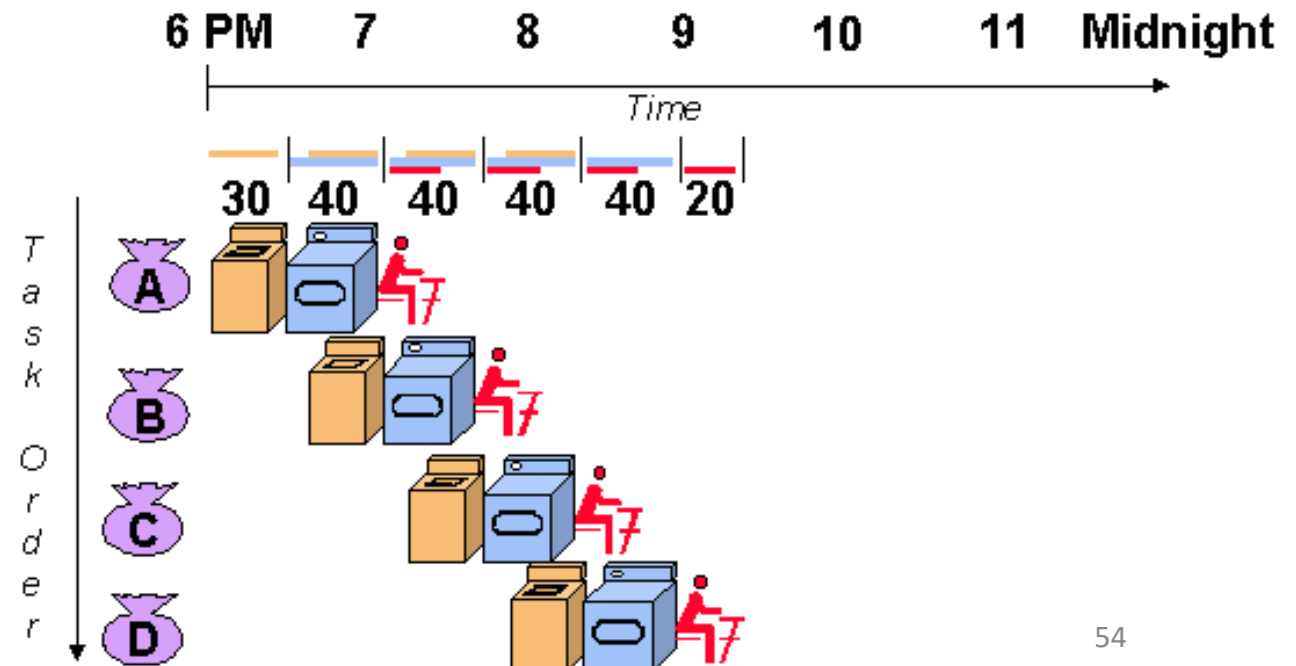
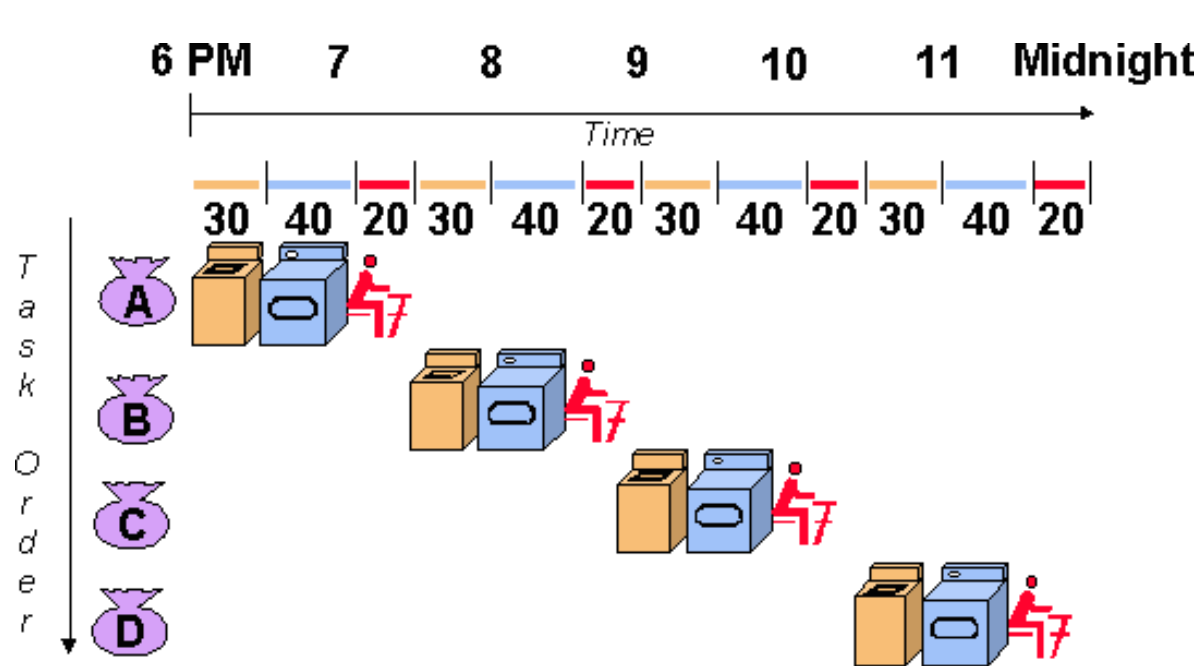

Techniques built into Contemporary Processors

1. Pipelining:

- a. Processor can simultaneously work on multiple instructions.
- b. The processor overlaps operations by moving data or instructions into a conceptual pipe with all stages of the pipe processing simultaneously.

For example, while one instruction is being executed, the computer is decoding the next instruction.

1. Branch Prediction:

- a. The processor looks ahead in the instruction code fetched from memory and predicts which branches, or groups of instructions, are likely to be processed next.
- b. If the processor guesses right most of the time, it can prefetch the correct instructions and buffer them so that the processor is kept busy.
- c. The more sophisticated examples of this strategy predict not just the next branch but multiple branches ahead. Thus, branch prediction increases the amount of work available for the processor to execute.

Techniques built into Contemporary Processors

3. **Data Flow Analysis:**

- a. The processor analyzes which instructions are dependent on each other's results, or data, to create an optimized schedule of instructions.
- b. Instructions are scheduled to be executed when ready, independent of the original program order.
This prevents unnecessary delay.

4. **Speculative execution:**

- a. Using branch prediction and data flow analysis, sometimes require holding the results in temporary locations.
- b. This enables the processor to keep its execution engines as busy as possible by executing instructions that are likely to be needed.

Reference

William Stallings, 2013. Computer Organization and Architecture, 9th Edition, Publisher: Pearson.



Computer
Organization
and Architecture
Designing for Performance
Ninth Edition

William Stallings